

DICOM Conformance Statement

RT Elements

Document Revision 7

September 9, 2020

2020 © Copyright Brainlab AG

1 Conformance Statement Overview

This is a Conformance Statement for the Brainlab Radiotherapy system. This system – dependent from purchased licenses and configuration – consists of several applications and performers.

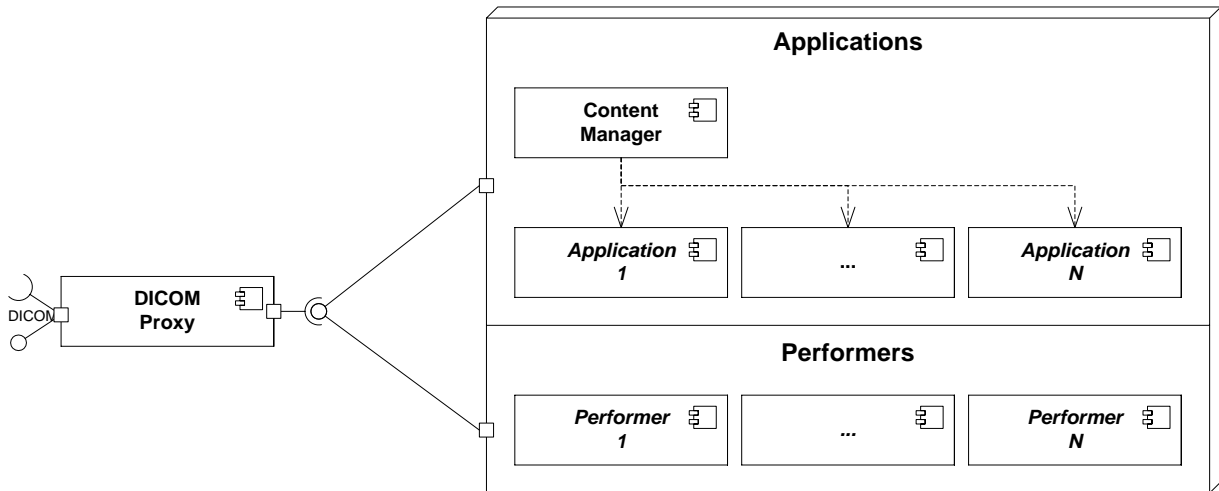

Figure 1-1: Overview of a Brainlab system running applications and performers

The Brainlab system is based on the following common management applications:

Management Application	Description
Content Manager	Manages applications on Brainlab systems. It allows a user to create and read screenshots. See [1] for the Conformance Statement.
DICOM Proxy	The interface between the Brainlab system and the outside DICOM world. No application or performer communicates directly with any remote DICOM node, but all communication will be done through the DICOM Proxy. If necessary the DICOM Proxy adjusts the DICOM communication to the capabilities and known specialties of the remote DICOM nodes. The DICOM Proxy itself (see [2] for the Conformance Statement) as well as the internal communication between the DICOM Proxy and the applications and performers is not part of this Conformance Statement.

Table 1-1: Common Management Applications

Applications have a user interface. The following applications are documented in this Conformance Statement:

Application	Description
RT Preparation	Allows the user to select the referenced image data set and define an external contour for radiotherapy treatment planning. The result can be used in other treatment planning Elements.
Multiple Brain Mets SRS	Allows the user to create an indication-driven radiotherapy treatment plan for multiple brain metastases. Final treatment plans can be exported to third-party systems for treatment or evaluation.

Application	Description
Cranial SRS	Allows the user to create an indication-driven radiotherapy treatment plan for intracranial lesions and arteriovenous malformations. Final treatment plans can be exported to third-party systems for treatment or evaluation.
Cranial SRS w/ Cones	Allows the user to create an indication-driven radiotherapy treatment plan for intracranial lesions and functional diseases. Final treatment plans can be exported to third-party systems for treatment or evaluation.
Spine SRS	Allows the user to create an indication-driven radiotherapy treatment plan for spinal metastases. Final treatment plans can be exported to third-party systems for treatment or evaluation.
Dose Review	Enables the user to review radiotherapeutic volume dose based on image and structure information.
RT QA	Allows the user to perform steps required for quality assurance of radiotherapy treatment plans.

Table 1-2: Applications

Performers don't have a user interface and perform their tasks in the background. The following performers are documented in this Conformance Statement:

Performer	Description
DICOM RT Export	Conversion of 3D objects and registration (fusion) data to DICOM RT compliant format.
DICOM RT Import	Conversion of DICOM RT Structure Set, DICOM RT Plan and DICOM RT Dose to internal format for positioning, review and planning.

Table 1-3: Performers

The following application are included in a Radiotherapy system but will not be documented here. See [1] for the Conformance Statement.

The following additional applications and performers are included in the Radiotherapy system but will not be documented here. See [1] for the Conformance Statement.

Application	Description
PDM	Allows the user to browse, load or save patient data (Content Manager, Patient Selection, Data Selection).
Viewer	Allows the user to view DICOM image data.
Image Fusion	Allows the user to co-register DICOM volumetric image data sets.
Image Fusion Angio	Allows the user to co-register angiographic x-ray images and volumetric image data sets.
Smartbrush	Allows the user to create, read and update segmentations based on DICOM image data.
Object Management	Allows the user to create, review and modify segmentation objects based on the Universal Atlas. Provides functionality to combine, subtract or intersect existing objects and to store the result as a new segmentation object.
Fibertracking	Allows the user to create, review and modify fiber bundles as surface segmentation objects. Allows to create simple manual ROIs as segmentation objects.
Trajectory Planning	Allows the user to define trajectories for surgical procedures.

Performer	Description
Auto Segmentation	Performs segmentation tasks in the background
Universal Atlas Performer	Performs deformable spatial registrations of datasets to the Brainlab Universal Atlas.

The table below addresses all supported network services used by the different radiotherapy application entities. For other applications, refer to [1]. For the SOP Classes in the Transfer section SCU and SCP have special meanings. Entities consuming data (e.g., for displaying images) are marked as SCP. Applications producing data (e.g., like spatial registrations) are marked as SCU. All created data will be initially stored to the DICOM Proxy, which then is responsible to forward created data to configured remote DICOM nodes.

- Symbol: Meaning:
- User of Service (SCU)
 - ◆ Provider of Service (SCP)
 - ✱ Both (SCU/SCP)

SOP Classes	RT Preparation	Multiple Brain Mets SRS	Cranial SRS	Cranial SRS w/ Cones	Spine SRS	Dose Review	RT-QA	DICOM RT Export Performer	DICOM RT Import Performer
Transfer									
CT Image Storage	◆	◆	◆	◆	◆	◆	◆	◆	◆
Grayscale Softcopy Presentation State Storage	◆	◆	◆	◆	◆	◆	◆		
Key Object Selection Document Storage	◆	◆	◆	◆	◆	◆	◆		■
MR Image Storage	◆	◆	◆	◆	◆	◆	◆	◆	◆
Parametric Map Storage		✱	✱	✱	✱	◆	✱		■
Raw Data Storage	✱	✱	✱	✱	✱	◆	✱		■
RT Dose Storage		■	■	■	■		■		◆
RT Plan Storage		■	■	■	■		■		◆
RT Structure Set Storage		■	■	■	■		■	■	◆
Segmentation Storage	✱	✱	✱	✱	✱	◆	✱	◆	■
Spatial Registration Storage	◆	◆	◆	◆	◆	◆	◆	◆	
Surface Segmentation Storage				✱					
Query/Retrieve									
Study Root Query/Retrieve Information Model - GET	■	■	■	■	■	■	■	■	■

Table 1-4: Supported network services

The next table addresses all supported Media Storage Application Profiles used by the different application entities.

- Symbol: Meaning:
- Read Files (FSR)
 - ◆ Write Files (FSC or FSU)
 - ✦ Both (FSR/FSC or FSU)

Media Storage Application Profile	RT Preparation	Multiple Brain Mets SRS	Cranial SRS	Cranial SRS w\ Cones	Spine SRS	RT-QA	DICOM RT Export Performer	DICOM RT Import Performer
Brainlab General Purpose Media Interchange		◆	◆	◆	◆	◆	◆	

Table 1-5: Supported media profiles

2 Table of Contents

1	Conformance Statement Overview	3
2	Table of Contents	9
3	Introduction	11
3.1	Revision History.....	11
3.2	Audience	11
3.3	Remarks.....	11
3.4	Abbreviations.....	12
3.5	References.....	12
4	Networking	15
4.1	Implementation Model	15
4.1.1	Application Data Flow Diagram	15
4.1.2	Functional Definition of Application Entity (AE)	16
4.1.3	Sequencing Of Real World Activities	18
4.2	Application Entity Specifications	20
4.2.1	Common Specifications.....	20
4.2.2	RT Preparation Application Specification.....	27
4.2.3	Multiple Brain Mets SRS Application Specification	29
4.2.4	Cranial SRS Application Specification	31
4.2.5	Cranial SRS w/ Cones Application Specification.....	33
4.2.6	Spine SRS Application Specification	35
4.2.7	Dose Review Application Specification.....	37
4.2.8	RT QA Application Specification.....	39
4.2.9	DICOM RT Export Performer Specification.....	41
4.2.10	DICOM RT Import Performer Specification.....	42
4.3	Network Interfaces.....	45
4.3.1	Physical Network Interface	45
4.3.2	Additional Protocols.....	45
4.4	Configuration	45
4.4.1	AE Title.....	45
5	Media Interchange	47
5.1	Implementation Model	47
5.1.1	Application Data Flow Diagram	47
5.1.2	Functional Definitions of AE's	47
5.1.3	Sequencing of Real-World Activities.....	47
5.1.4	File Meta Information Options.....	47
5.2	AE Specifications.....	48
5.2.1	Common Export Specifications.....	48
5.3	Augmented and Private Application Profiles	49
5.3.1	Augmented Application Profiles	49
5.3.2	Private Application Profiles.....	49
6	Support of Character Sets	51
7	Security Profiles	53
7.1	Security Profiles.....	53
7.2	Association Level Security.....	53
7.3	Application Level Security.....	53

8	Annexes	55
8.1	IOD Contents.....	55
8.1.1	Supported SOP Instances	55
8.1.2	Supported Modules	57
8.1.3	Usage of Attributes from Received IODs	71
8.1.4	Attribute Mapping	72
8.1.5	Coerced/Modified fields	72
8.2	Data Dictionary of Private Attributes	73
8.2.1	Group 0009	73
8.2.2	Group 3243	73
8.2.3	Group 3249	73
8.2.4	Group 3253	73
8.3	Coded Terminology and Templates	74
8.4	Grayscale Image Consistency	75
8.5	Standard Extended/Specialized/Private SOP Classes	76
8.6	Private Transfer Syntaxes	77
9	Indexes	79
9.1	Index of Tables	79
9.2	Index of Figures	80

3 Introduction

3.1 Revision History

Document Revision	Date of Issue	Author	Description
-------------------	---------------	--------	-------------

3.2 Audience

This document is intended for hospital staff, health system integrators, software designers or implementers. It is assumed that the reader has a working understanding of DICOM.

3.3 Remarks

DICOM, by itself, does not guarantee interoperability. However, the Conformance Statement facilitates a first-level validation for interoperability between different applications supporting the same DICOM functionality. The Conformance Statement should be read and understood in conjunction with the DICOM Standard [3]. However, by itself it is not guaranteed to ensure the desired interoperability and a successful interconnectivity.

The user should be aware of the following important issues:

- The comparison of different Conformance Statements is the first step towards assessing interconnectivity between Brainlab and non–Brainlab equipment.
- This Conformance Statement is not intended to replace validation with other DICOM equipment to ensure proper exchange of information intended.
- The DICOM standard will evolve to meet the users' future requirements. Brainlab reserves the right to make changes to its products or to discontinue its delivery.

3.4 Abbreviations

There are a variety of terms and abbreviations used in the document that are defined in the DICOM Standard. Abbreviations and terms are as follows:

AE	DICOM Application Entity
AET	Application Entity Title
CD	Compact Disk
CD-R	Compact Disk Recordable
DVD	Digital Versatile Disc
FSC	File-Set Creator
FSU	File-Set Updater
FSR	File-Set Reader
HD	Hard Disk
IOD	(DICOM) Information Object Definition
ISO	International Standard Organization
MOD	Magneto Optical Disk
PDU	DICOM Protocol Data Unit
Q/R	Query and Retrieve
RT	Radiotherapy
SCU	DICOM Service Class User (DICOM client)
SCP	DICOM Service Class Provider (DICOM server)
SOP	DICOM Service-Object Pair

3.5 References

- [1] Brainlab AG, "DICOM Conformance Statement Surgery 7.0," 2018. [Online]. Available: <https://www.brainlab.com/wp-content/uploads/2018/05/DICOM-Conformance-Statement-Surgery-Rev7.pdf>.
- [2] Brainlab AG, "DICOM Conformance Statement DICOM Proxy 4.1," 2018. [Online]. Available: <https://www.brainlab.com/wp-content/uploads/2018/05/DICOM-Conformance-Statement-DICOM-Proxy-4.1.pdf>.
- [3] D. S. Committee, "Digital Imaging and Communications in Medicine (DICOM) 3.0, Rev. 2020c," Medical Imaging & Technology Alliance (MITA), 2020. [Online]. Available: <http://www.dicomstandard.org/current/>.
- [4] Brainlab AG, "DICOM Conformance Statement RT Elements 2.0," 2018. [Online]. Available: <https://www.brainlab.com/wp-content/uploads/2018/05/DICOM-Conformance-Statement-RT-Elements-Rev4.pdf>.

-
- [5] Varian Medical Systems, "Varian System Server 16.0 DICOM Conformance Statement," 2020. [Online]. Available: https://p.widencdn.net/1iyw3/VarianSystemServer16.0DICOM_ConformanceStatement.
- [6] IHE, IHE RO Technical Framework: Multimodality Image Registration for Radiation Oncology, IHE, 2012.

4 Networking

4.1 Implementation Model

4.1.1 Application Data Flow Diagram

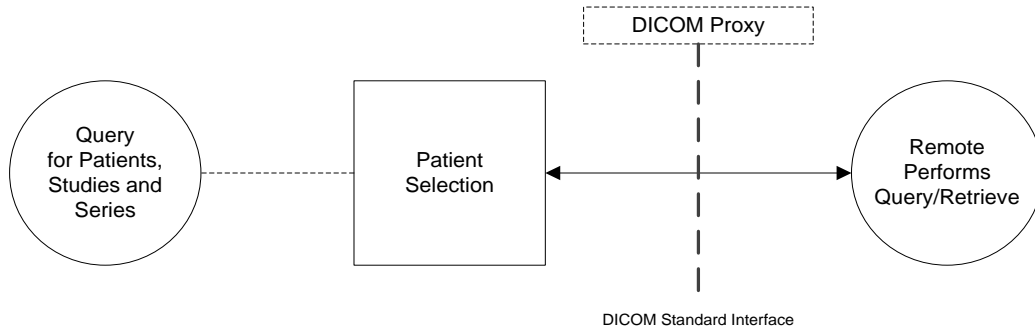

Figure 4-1: Patient Selection Application Data Flow Diagram

Brainlab applications in general support several data flows. Either they receive any DICOM data to display it, to process it and/or to create new DICOM data.

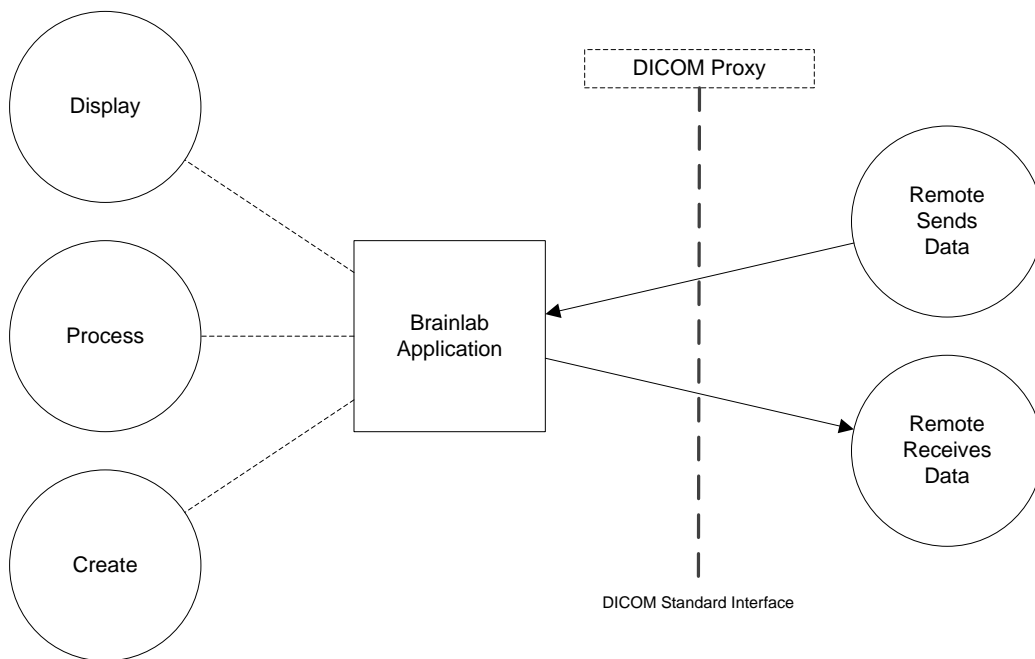

Figure 4-2: General Application Data Flow Diagram

Brainlab Performers only have one data flow. They process received DICOM data and create new DICOM data out of it.

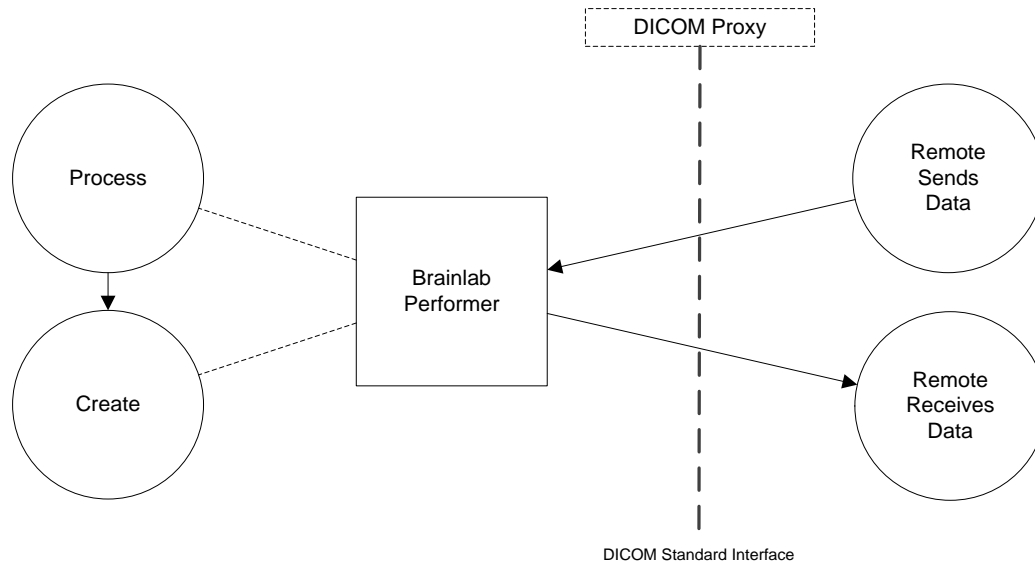

Figure 4-3: General Performer Data Flow Diagram

4.1.2 Functional Definition of Application Entity (AE)

All communication is done through the DICOM Proxy. If there is an appropriate configuration for a remote node any DICOM command or message may be forwarded to the configured remote node. In this case the DICOM Proxy may act as protocol converter, i.e., it converts DICOM commands and messages in a DICOM format the remote node understands.

If there is no remote node configured the data will be retrieved from and stored in the local storage of the DICOM Proxy.

4.1.2.1 Applications

4.1.2.2 Management Applications

- **Content Manager**

It allows the user to create screenshots. It stores them via the DICOM Storage Service Class as DICOM Secondary Capture.

4.1.2.3 Applications

- **Multiple Brain Mets SRS**

The Multiple Brain Mets SRS application provides optimized planning and display for cranial multi-metastases radiation planning. It requests DICOM image, Segmentation, Registration, Key Object Selection and Raw Data instances received via the DICOM Storage Service Class. It creates Segmentation, Key Object Selection and Raw Data instances. DICOM RT Structure Set, RT Plan and RT Dose instances are created during export and sent along the image instances to a defined target system.

- **Cranial SRS**
The Cranial SRS application provides optimized radiation treatment planning for intracranial lesions and arteriovenous malformations (AVM). It requests DICOM image, Segmentation, Registration, Key Object Selection and Raw Data instances received via the DICOM Storage Service Class. It creates Segmentation, Key Object Selection and Raw Data instances. DICOM RT Structure Set, RT Plan and RT Dose instances are created during export and sent along the image instances to a defined target system.
- **Spine SRS**
The Spine SRS application provides optimized radiation treatment planning for spinal metastases. It requests DICOM image, Segmentation, Registration, Key Object Selection and Raw Data instances received via the DICOM Storage Service Class. It creates Segmentation, Key Object Selection and Raw Data instances. DICOM RT Structure Set, RT Plan and RT Dose instances are created during export and sent along the image instances to a defined target system.
- **RT QA**
The RT QA application provides means for verification of beam models as well as patient specific quality assurance. It requests DICOM image, Segmentation, Registration, Key Object Selection and Raw Data instances received via the DICOM Storage Service Class. It creates Segmentation, Key Object Selection and Raw Data instances. DICOM RT Structure Set, RT Plan and RT Dose instances are created during export and sent along the image instances to a defined target system.
- **Dose Review**
The Dose Review application contains features for review of isodose lines, review of DVHs, dose comparison and summation. It requests DICOM image, Segmentation, Registration, Key Object Selection and Raw Data instances received via the DICOM Storage Service Class. It does not create any new DICOM instances.

For the following Applications, refer to [1]:

- **PDM**
- **Viewer**
- **Image Fusion**
- **Image Fusion Angio**
- **Smartbrush**
- **Object Management**
- **Fibertracking**
- **Trajectory Planning**

4.1.2.4 Performer

- **DICOM RT Export**
Background service to export DICOM RT Structure Sets for contouring workflows.
- **DICOM RT Import**
Background service to import DICOM RT Structure Sets, DICOM RT Plans and DICOM RT Dose for contouring, positioning, review and Registry workflows.

For the following Performers, refer to [1]:

- Vessel Segmentation
- Universal Atlas

4.1.3 Sequencing Of Real World Activities

4.1.3.1 Standard Interactive Use Case

In the standard use case normally the user selects a patient in the Patient Selection Application or some data to work with (1). Afterwards, the application is started (2) and requests the data (3). The DICOM Proxy retrieves from the configured remote nodes¹ the requested data (4) and passes it through to the requesting application (5).

If the application creates any data it optionally will be sent to a remote system (6).

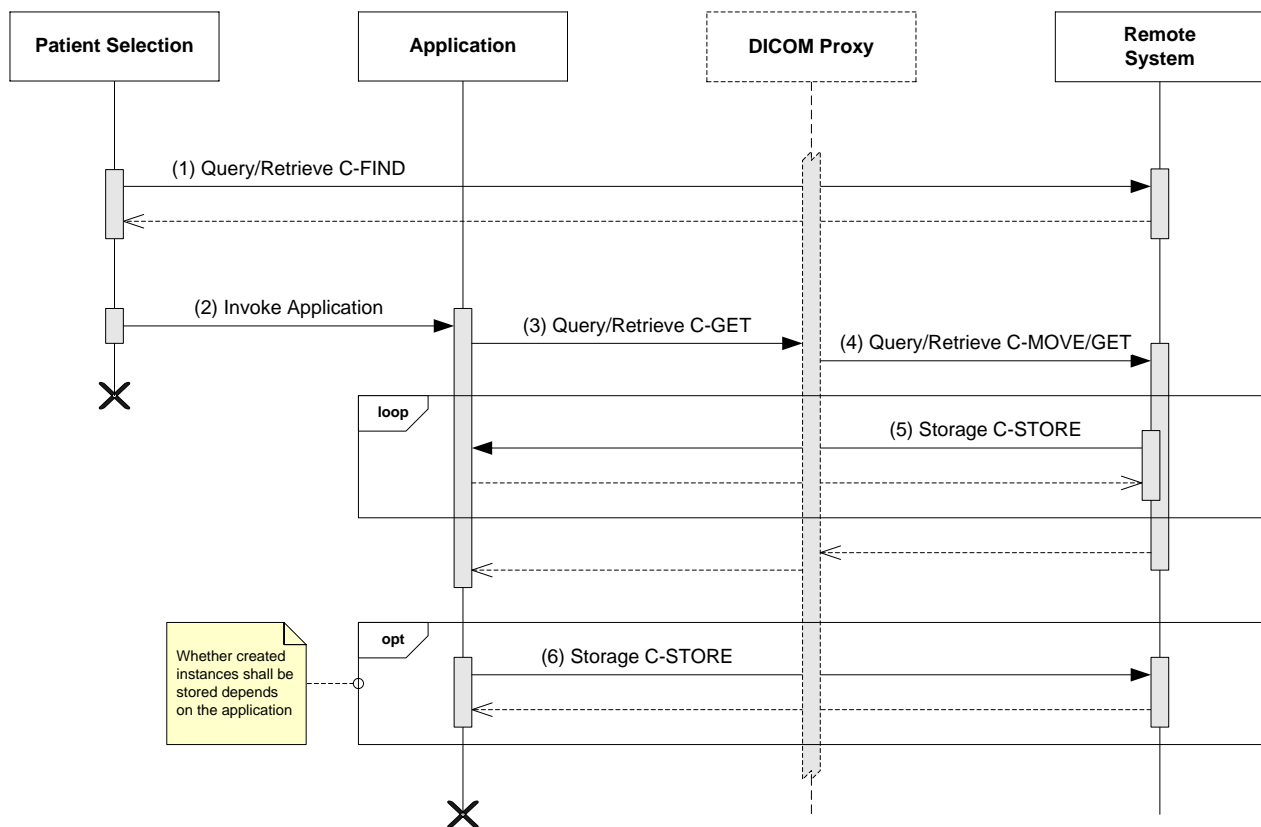

Figure 4-4: Simplified sequencing of the standard interactive use case.

The sequencing is not only possible between the Patient Selection and an Application but also between two or more different applications, i.e., it is possible to build a chain of applications, each performing a special task. This chain then is controlled by the Content Manager.

¹ The DICOM Proxy adjusts all queries to the addressed remote node, e.g., it automatically converts Query/Retrieve C-GET requests for nodes not supporting this command to C-MOVE requests.

4.1.3.2 Performer

In general a performer is invoked as soon as new data arrives at the DICOM Proxy (1). Via internal communication (not part of this Conformance Statement) the Performer is informed about the new data and - if it is able to process the data – requests it (3,4). The Performer processes the data (5) and, if the Performer creates new instances, it can send the created data to the DICOM Proxy, which may automatically forward it to a remote node (6).

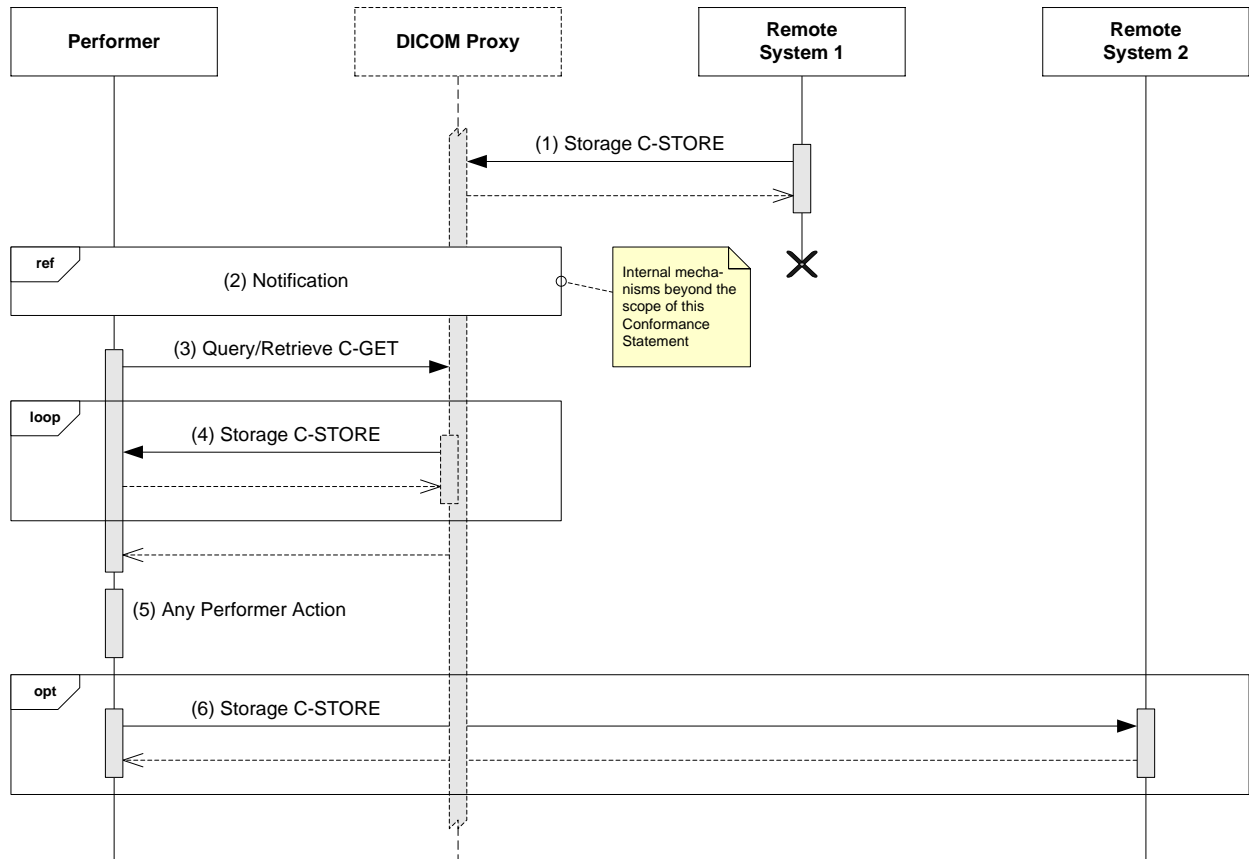

Figure 4-5: Simplified sequencing of Performer activities.

4.2 Application Entity Specifications

4.2.1 Common Specifications

This section contains the specifications valid for all application entities in this Conformance Statement. In successive application entity sections only the differences or additional information will be described.

4.2.1.1 SOP Classes and Transfer Syntaxes

This section only defines the commonly used SOP Classes and Transfer Syntaxes. Whether they are supported as SCU or SCP will be described in the sub sections of the appropriate application entity.

In the following table all transfer syntaxes supported by any of the applications are listed:

List Name / Transfer Syntax Name	List Short Name / Transfer Syntax UID
Transfer Syntax List With No Compression	NOCOMP
DICOM Explicit VR Little Endian	1.2.840.10008.1.2.1
DICOM Explicit VR Big Endian	1.2.840.10008.1.2.2
DICOM Implicit VR Little Endian	1.2.840.10008.1.2
Transfer Syntax List With Lossless Compression	COMP
<i>Include Transfer Syntax List NOCOMP</i>	
JPEG Lossless, Non-Hierarchical, First-Order Prediction (Process 14)	1.2.840.10008.1.2.4.70
RLE Lossless	1.2.840.10008.1.2.5
Transfer Syntax List with RLE Compression	RLE
RLE Lossless	1.2.840.10008.1.2.5
<i>Include Transfer Syntax List NOCOMP</i>	
Transfer Syntax List With Lossy Compression	LOSSY
<i>Include Transfer Syntax List NOCOMP</i>	
JPEG Baseline (Process 1)	1.2.840.10008.1.2.4.50
Transfer Syntax List with MPEG2	MPEG2
<i>Include Transfer Syntax List NOCOMP</i>	
MPEG2 Main Profile @ Main Level	1.2.840.10008.1.2.4.100
Transfer Syntax List with MPEG4	MPEG4
<i>Include Transfer Syntax List NOCOMP</i>	
MPEG-4 AVC/H.264 High Profile / Level 4.1	1.2.840.10008.1.2.4.102

Table 4-1: Commonly supported Transfer Syntaxes (for association negotiation)

The transfer syntaxes are organized in so-called transfer syntax lists. For each presentation context specified by an application or performer, the name respectively short name of the transfer syntax list is mentioned instead of repeating all the transfer syntaxes.

Some applications and performers support the DICOM Storage Service Class. The following table contains the superset of supported Storage SOP Classes with the mapping to the accepted respectively proposed transfer syntax list.

SOP Class Name	SOP Class UID	Transfer Syntax List
Image Storage SOP Classes		
Breast Tomosynthesis Image Storage	1.2.840.10008.5.1.4.1.1.13.1.3	COMP
Computed Radiography Image Storage	1.2.840.10008.5.1.4.1.1.1	COMP
CT Image Storage	1.2.840.10008.5.1.4.1.1.2	COMP
Digital Intra-oral X-Ray Image Storage - For Presentation	1.2.840.10008.5.1.4.1.1.1.3	COMP
Digital Intra-oral X-Ray Image Storage - For Processing	1.2.840.10008.5.1.4.1.1.1.3.1	COMP
Digital Mammography X-Ray Image Storage - For Presentation	1.2.840.10008.5.1.4.1.1.1.2	COMP
Digital Mammography X-Ray Image Storage - For Processing	1.2.840.10008.5.1.4.1.1.1.2.1	COMP
Digital X-Ray Image Storage - For Presentation	1.2.840.10008.5.1.4.1.1.1.1	COMP
Digital X-Ray Image Storage - For Processing	1.2.840.10008.5.1.4.1.1.1.1.1	COMP
Enhanced CT Image Storage	1.2.840.10008.5.1.4.1.1.2.1	COMP
Enhanced MR Color Image Storage	1.2.840.10008.5.1.4.1.1.4.3	COMP
Enhanced MR Image Storage	1.2.840.10008.5.1.4.1.1.4.1	COMP
Enhanced PET Image Storage	1.2.840.10008.5.1.4.1.1.130	COMP
Enhanced US Volume Storage	1.2.840.10008.5.1.4.1.1.6.2	COMP
Enhanced XA Image Storage	1.2.840.10008.5.1.4.1.1.12.1.1	COMP
Enhanced XRF Image Storage	1.2.840.10008.5.1.4.1.1.12.2.1	COMP
Intravascular Optical Coherence Tomography Image Storage - For Presentation	1.2.840.10008.5.1.4.1.1.14.1	COMP
Intravascular Optical Coherence Tomography Image Storage - For Processing	1.2.840.10008.5.1.4.1.1.14.2	COMP
MR Image Storage	1.2.840.10008.5.1.4.1.1.4	COMP
MR Spectroscopy Storage	1.2.840.10008.5.1.4.1.1.4.2	COMP
Multi-frame Grayscale Byte Secondary Capture Storage	1.2.840.10008.5.1.4.1.1.7.2	COMP
Multi-frame Grayscale Word Secondary Capture Storage	1.2.840.10008.5.1.4.1.1.7.3	COMP
Multi-frame Single Bit Secondary Capture Storage	1.2.840.10008.5.1.4.1.1.7.1	COMP
Multi-frame True Color Secondary Capture Storage	1.2.840.10008.5.1.4.1.1.7.4	LOSSY
Nuclear Medicine Image Storage	1.2.840.10008.5.1.4.1.1.20	COMP
Nuclear Medicine Image Storage (Retired)	1.2.840.10008.5.1.4.1.1.5	COMP
Ophthalmic Photography 16 Bit Image Storage	1.2.840.10008.5.1.4.1.1.77.1.5.2	COMP
Ophthalmic Photography 8 Bit Image Storage	1.2.840.10008.5.1.4.1.1.77.1.5.1	COMP
Ophthalmic Tomography Image Storage	1.2.840.10008.5.1.4.1.1.77.1.5.4	COMP
Parametric Map Storage	1.2.840.10008.5.1.4.1.1.30	NOCOMP
Positron Emission Tomography Image Storage	1.2.840.10008.5.1.4.1.1.128	COMP
Secondary Capture Image Storage	1.2.840.10008.5.1.4.1.1.7	COMP
Ultrasound Image Storage	1.2.840.10008.5.1.4.1.1.6.1	COMP
Ultrasound Image Storage (Retired)	1.2.840.10008.5.1.4.1.1.6	COMP
Ultrasound Multi-frame Image Storage	1.2.840.10008.5.1.4.1.1.3.1	COMP
Ultrasound Multi-frame Image Storage (Retired)	1.2.840.10008.5.1.4.1.1.3	COMP

SOP Class Name	SOP Class UID	Transfer Syntax List
Video Endoscopic Image Storage	1.2.840.10008.5.1.4.1.1.77.1.1.1	MPEG2
Video Microscopic Image Storage	1.2.840.10008.5.1.4.1.1.77.1.2.1	MPEG2
Video Photographic Image Storage	1.2.840.10008.5.1.4.1.1.77.1.4.1	MPEG2/MPEG 4
VL Endoscopic Image Storage	1.2.840.10008.5.1.4.1.1.77.1.1	COMP
VL Microscopic Image Storage	1.2.840.10008.5.1.4.1.1.77.1.2	COMP
VL Photographic Image Storage	1.2.840.10008.5.1.4.1.1.77.1.4	COMP
VL Slide-Coordinates Microscopic Image Storage	1.2.840.10008.5.1.4.1.1.77.1.3	COMP
VL Whole Slide Microscopy Image Storage	1.2.840.10008.5.1.4.1.1.77.1.6	COMP
X-Ray 3D Angiographic Image Storage	1.2.840.10008.5.1.4.1.1.13.1.1	COMP
X-Ray 3D Craniofacial Image Storage	1.2.840.10008.5.1.4.1.1.13.1.2	COMP
X-Ray Angiographic Bi-Plane Image Storage (Retired)	1.2.840.10008.5.1.4.1.1.12.3	COMP
X-Ray Angiographic Image Storage	1.2.840.10008.5.1.4.1.1.12.1	COMP
X-Ray Radiofluoroscopic Image Storage	1.2.840.10008.5.1.4.1.1.12.2	COMP
Non-Image Storage SOP Classes		
Deformable Spatial Registration Storage	1.2.840.10008.5.1.4.1.1.66.3	NOCOMP
Encapsulated PDF Storage	1.2.840.10008.5.1.4.1.1.104.1	NOCOMP
Grayscale Softcopy Presentation State Storage	1.2.840.10008.5.1.4.1.1.11.1	NOCOMP
Key Object Selection Document Storage	1.2.840.10008.5.1.4.1.1.88.59	NOCOMP
Raw Data Storage	1.2.840.10008.5.1.4.1.1.66	NOCOMP
RT Dose Storage	1.2.840.10008.5.1.4.1.1.481.2	IMPL ²
RT Plan Storage	1.2.840.10008.5.1.4.1.1.481.5	IMPL ²
RT Structure Set Storage	1.2.840.10008.5.1.4.1.1.481.3	IMPL ²
Segmentation Storage	1.2.840.10008.5.1.4.1.1.66.4	RLE
Spatial Fiducials Storage	1.2.840.10008.5.1.4.1.1.66.2	NOCOMP
Spatial Registration Storage	1.2.840.10008.5.1.4.1.1.66.1	NOCOMP
Surface Segmentation Storage	1.2.840.10008.5.1.4.1.1.66.5	NOCOMP

Table 4-2: Superset of supported Storage SOP Classes with Transfer Syntax mapping

Some applications and performers support the DICOM Query/Retrieve Service Class. The following table contains the superset of supported Query/Retrieve SOP Classes with the mapping to the accepted respectively proposed transfer syntax list.

SOP Class Name	SOP Class UID	Transfer Syntax List
FIND SOP Classes		
Patient Root Query/Retrieve Information Model – FIND	1.2.840.10008.5.1.4.1.2.1.1	NOCOMP
Study Root Query/Retrieve Information Model – FIND	1.2.840.10008.5.1.4.1.2.2.1	NOCOMP

² RT Dose, RT Plan and RT Structure Set Instances contain attributes with a VR of DS and a VM of 1-n (e.g., Contour Data (3006,0050) in RT Structure Sets). Implicit Little Endian transfer syntax allows storing of those attributes with a doubled length in comparison to explicit transfer syntax (4 byte length field vs. 2 byte length field).

SOP Class Name	SOP Class UID	Transfer Syntax List
GET SOP Classes		
Patient Root Query/Retrieve Information Model – GET	1.2.840.10008.5.1.4.1.2.1.3	NOCOMP
Study Root Query/Retrieve Information Model – GET	1.2.840.10008.5.1.4.1.2.2.3	NOCOMP

Table 4-3: Superset of supported Query/Retrieve SOP Classes with Transfer Syntax mapping

The usage of these SOP Classes is specified in the sections with the detailed application specifications.

4.2.1.2 Association Policies

4.2.1.2.1 General

The DICOM standard application context name for DICOM 3.0 is always proposed:

Application Context Name	1.2.840.10008.3.1.1.1
--------------------------	-----------------------

Table 4-4: Commonly proposed Application Context Name

4.2.1.2.2 Number of Associations

Maximum number of simultaneous Associations (Initiator)	10 (configurable)
Maximum number of simultaneous Associations (Acceptor)	10 (configurable)

Table 4-5: Commonly supported number of associations

4.2.1.2.3 Asynchronous Nature

Applications or performers by default do not support asynchronous communication (multiple outstanding transactions over a single association). However if it is supported it is mentioned in the section of the affected application entity.

4.2.1.2.4 Implementation Identifying Information

The implementation information for the application entities described in this document normally is hidden by the Brainlab DICOM Proxy (see [2] for its implementation identifying information). Therefore this information in the sections of the different application entities is purely informational.

4.2.1.3 Association Initiation Policy

Brainlab applications and performers initiate associations in these cases:

- Find Studies, Series and Instances
Initiated by applications and performers to find related studies, series and instances
- Get Studies, Series and Instances
Initiated by applications and performers to retrieve related studies, series and instances

If one of these activities is supported it is mentioned in the subsection of the appropriate application entity.

4.2.1.3.1 Activity – Find Studies, Series and Instances

4.2.1.3.1.1 Description and Sequencing of Activities

Brainlab applications or performers initiate an association with the intention to find studies, series or instances and to retrieve them, e.g., because they are related to or referenced by a loaded data set.

4.2.1.3.1.2 Proposed Presentation Contexts

Presentation Context Table				
Abstract Syntax		Transfer Syntax	Role	Ext. Neg
Patient Root Query/Retrieve Information Model - FIND	1.2.840.10008.5.1.4.1.2.1.1	See Table 4-3 for the SOP Class / Transfer Syntax mapping	SCU	None
Study Root Query/Retrieve Information Model – FIND	1			

Table 4-6: Commonly proposed Presentation Contexts - Find Studies, Series and Instances.

4.2.1.3.1.3 SOP Specific Conformance

Brainlab applications and performers provide standard conformance to the Patient and Study Root Query/Retrieve Information Model – FIND SOP Classes. No extended negotiation is implemented.

A C-FIND can be executed on all levels. On a lower level, all key attributes of the higher levels are included in the query (i.e. no relational queries are performed).

Attribute Name	Tag	Types of Matching
Patient Level (Patient Root Q/R Information Model) / Study Level (Study Root Q/R Information Model)		
Patient's Name	(0010,0010)	S, *, U
Patient ID	(0010,0020)	S, *, U
Patient's Birth Date	(0010,0030)	U
Patient's Sex	(0010,0040)	U
Study Level		
Study Date	(0008,0020)	S, R, U
Accession Number	(0008,0050)	S, *, U
Referring Physician's Name	(0008,0090)	S, *, U
Study Instance UID	(0020,000D)	UNIQUE
Study Time	(0008,0030)	U
Study Description	(0008,1030)	U
Modalities in Study	(0008,0061)	U
SOP Classes in Study	(0008,0062)	U
Number of Study Related Series	(0020,1206)	U
Series Level		
Series Instance UID	(0020,000E)	UNIQUE
Series Number	(0020,0011)	U
Series Description	(0008,103E)	U
Series Date	(0008,0020)	U

Attribute Name	Tag	Types of Matching
Series Time	(0008,0021)	U
Modality	(0008,0060)	U
No. of Series Rel. Instances	(0020,1209)	U
Instance Level		
SOP Instance UID	(0008,0018)	UNIQUE
SOP Class UID	(0008,0016)	U
Instance Number	(0020,0013)	U
Instance Creation Date	(0008,0012)	U
Instance Creation Time	(0008,0013)	U
Arbitrary Search Keys as Requested by the Client	*	U

Table 4-7: Patient Root and Study Root Request Identifier for FIND-SCU

The types of Matching supported by the C-FIND SCU:

- “S” Single value matching
- “R” Range matching
- “*” Wildcard matching
- “U” Universal matching
- “L” UID list matching
- “UNIQUE” The unique key for the query level, (i.e. single value matching for levels below the current query level, either universal or single value matching for the current query level)

4.2.1.3.2 Activity – Get Studies, Series and Instances

4.2.1.3.2.1 Description and Sequencing of Activities

If the find operation doesn't provide icons for queried instances the Patient Selection automatically retrieves the instances and creates previews.

4.2.1.3.2.2 Proposed Presentation Contexts

Presentation Context Table				
Abstract Syntax		Transfer Syntax	Role	Ext. Neg
Patient Root Query/Retrieve Information Model - GET	1.2.840.10008.5.1.4.1.2.1.3	See Table 4-3 for the SOP Class / Transfer Syntax mapping	SCU	None
Study Root Query/Retrieve Information Model - GET	1.2.840.10008.5.1.4.1.2.2.3			
All SCP Storage SOP Classes and SOP Class UIDs as defined in the respective application or performer specification		See Table 4-2 for the SOP Class / Transfer Syntax mapping	SCP	None

Table 4-8: Patient Selection proposed Presentation Contexts – Find Patient

4.2.1.3.2.3 SOP Specific Conformance

The Patient Selection provides standard conformance to the DICOM Patient and Study Root Query/Retrieve - GET SOP Class and to the DICOM Storage SOP Classes. No extended negotiation is implemented.

4.2.1.4 Association Acceptance Policy

Brainlab applications and performers do not directly accept associations. All external communication is handled by the DICOM Proxy (see [2] for details).

Nevertheless in the sub sections of the different application entities the association acceptance will be described to define the SOP Classes they support.

4.2.1.4.1 Transfer Syntax Selection Policy

Brainlab applications and performers in general accept transfer syntaxes in with no compression (explicit before implicit) before those with lossless compression and at least those with lossy compression. At least the order of the transfer syntaxes in the assigned transfer syntax list is the order of acceptance.

4.2.2 RT Preparation Application Specification

The RT Preparation application allows the preparation of patient information for radiation treatment planning. It requests DICOM image, Segmentation, Registration and Raw Data instances from the DICOM Proxy. It creates DICOM Raw Data instances and sends these to the DICOM Proxy.

4.2.2.1 SOP Classes and Transfer Syntaxes

The RT Preparation Application accepts the following SOP Classes:

SOP Class Name	SOP Class UID	SCU	SCP
Storage			
CT Image Storage	1.2.840.10008.5.1.4.1.1.2	No	Yes
MR Image Storage	1.2.840.10008.5.1.4.1.1.4	No	Yes
PET Image Storage	1.2.840.10008.5.1.4.1.1.128	No	Yes
Volumetric Other			
Segmentation Storage	1.2.840.10008.5.1.4.1.1.66.4	Yes	Yes
Spatial Registration Storage	1.2.840.10008.5.1.4.1.1.66.1	No	Yes
Raw Data Storage	1.2.840.10008.5.1.4.1.1.66	Yes	Yes
Other			
Grayscale Softcopy Presentation State	1.2.840.10008.5.1.4.1.1.11.1	No	Yes
Key Object Selection Document Storage	1.2.840.10008.5.1.4.1.1.88.59	Yes	Yes
Query/Retrieve			
Study Root Query/Retrieve Information Model – GET	1.2.840.10008.5.1.4.1.2.2.3	Yes	No

Table 4-9: RT Preparation Application supported SOP Classes

4.2.2.2 Association Policies

4.2.2.2.1 Implementation Identifying Information

The implementation information for this Application Entity is:

Implementation Class UID	1.2.276.0.20.1.1.107.<version>
Implementation Version Name	RTPreparation<version>

Current possible versions are: <version> = 3.0

4.2.2.3 Association Initiation Policy

The RT Preparation Application initiates an association in these cases:

- Find Studies, Series and Instances
Initiated to find related studies, series and instances
- Get Studies, Series and Instances
Initiated to retrieve related studies, series and instances

- Save Instances
The user created a new radiotherapy treatment plan.

4.2.2.3.1 Activity – Find Studies, Series and Instances

See Common Specifications, section 4.2.1.3.1.

4.2.2.3.2 Activity – Get Studies, Series and Instances

See Common Specifications, section 4.2.1.3.1., restricted to Study Root Query/Retrieve Information Model – GET and to all SCP Storage SOP Classes and SOP Class UIDs as listed in Table 4-11.

4.2.2.3.3 Activity – Save Instances

4.2.2.3.3.1 Description and Sequencing of Activities

New instances will be created if the user

- Saves a treatment plan. This will be stored as a Key Object Selection Document, Raw Data and Segmentation.

4.2.2.3.3.2 Proposed Presentation Contexts

Presentation Context Table			
Abstract Syntax	Transfer Syntax	Role	Ext. Neg
All SCU Storage SOP Classes and SOP Class UIDs as listed in Table 4-11	See Table 4-2 for the SOP Class / Transfer Syntax mapping	SCU	None

Table 4-10: RT Preparation Application proposed Presentation Contexts – Save Instances

4.2.2.3.3.3 SOP Specific Conformance

The RT Preparation Application provides standard conformance to the DICOM Storage SOP Classes.

4.2.3 Multiple Brain Mets SRS Application Specification

The Multiple Brain Mets SRS application provides optimized planning and display for cranial multi-metastases radiation planning. It requests DICOM image, Segmentation, Registration and Raw Data instances from the DICOM Proxy. It creates DICOM RT Structure Set, RT Plan and RT Dose instances and sends these along the image instances to a defined target system.

4.2.3.1 SOP Classes and Transfer Syntaxes

The Multiple Brain Mets SRS Application accepts the following SOP Classes:

SOP Class Name	SOP Class UID	SCU	SCP
Storage			
CT Image Storage	1.2.840.10008.5.1.4.1.1.2	No	Yes
MR Image Storage	1.2.840.10008.5.1.4.1.1.4	No	Yes
PET Image Storage	1.2.840.10008.5.1.4.1.1.128	No	Yes
Volumetric Other			
Segmentation Storage	1.2.840.10008.5.1.4.1.1.66.4	Yes	Yes
Spatial Registration Storage	1.2.840.10008.5.1.4.1.1.66.1	No	Yes
Raw Data Storage	1.2.840.10008.5.1.4.1.1.66	Yes	Yes
Parametric Map	1.2.840.10008.5.1.4.1.1.30	Yes	Yes
RT Dose Storage	1.2.840.10008.5.1.4.1.1.481.2	Yes	No
RT Plan Storage	1.2.840.10008.5.1.4.1.1.481.5	Yes	No
RT Structure Set Storage	1.2.840.10008.5.1.4.1.1.481.3	Yes	No
Other			
Grayscale Softcopy Presentation State	1.2.840.10008.5.1.4.1.1.11.1	No	Yes
Key Object Selection Document Storage	1.2.840.10008.5.1.4.1.1.88.59	Yes	Yes
Query/Retrieve			
Study Root Query/Retrieve Information Model – GET	1.2.840.10008.5.1.4.1.2.2.3	Yes	No

Table 4-11: Multiple Brain Mets SRS Application supported SOP Classes

4.2.3.2 Association Policies

4.2.3.2.1 Implementation Identifying Information

The implementation information for this Application Entity is:

Implementation Class UID	1.2.276.0.20.1.1.106.<version>
Implementation Version Name	DosePlanning<version>

Current possible versions are: <version> = 3.0

4.2.3.3 Association Initiation Policy

The Multiple Brain Mets SRS Application initiates an association in these cases:

- Find Studies, Series and Instances
Initiated to find related studies, series and instances
- Get Studies, Series and Instances
Initiated to retrieve related studies, series and instances
- Save Instances
The user created a new radiotherapy treatment plan.

4.2.3.3.1 Activity – Find Studies, Series and Instances

See Common Specifications, section 4.2.1.3.1.

4.2.3.3.2 Activity – Get Studies, Series and Instances

See Common Specifications, section 4.2.1.3.1., restricted to Study Root Query/Retrieve Information Model – GET and to all SCP Storage SOP Classes and SOP Class UIDs as listed in Table 4-11.

4.2.3.3.3 Activity – Save Instances

4.2.3.3.3.1 Description and Sequencing of Activities

New instances will be created if the user

- Saves a treatment plan. This will be stored as a Key Object Selection Document, Raw Data and Segmentation
- Exports a radiotherapy treatment plan.

4.2.3.3.3.2 Proposed Presentation Contexts

Presentation Context Table			
Abstract Syntax	Transfer Syntax	Role	Ext. Neg
All SCU Storage SOP Classes and SOP Class UIDs as listed in Table 4-11	See Table 4-2 for the SOP Class / Transfer Syntax mapping	SCU	None

Table 4-12: Multiple Brain Mets SRS Application proposed Presentation Contexts – Save Instances

4.2.3.3.3.3 SOP Specific Conformance

The Multiple Brain Mets SRS Application provides standard conformance to the DICOM Storage SOP Classes.

4.2.4 Cranial SRS Application Specification

The Cranial SRS application provides optimized radiation treatment planning for intracranial lesions and arteriovenous malformation (AVM). It requests DICOM image, Segmentation, Registration and Raw Data instances from the DICOM Proxy. It creates DICOM RT Structure Set, RT Plan and RT Dose instances and sends these along the image instances to a defined target system.

4.2.4.1 SOP Classes and Transfer Syntaxes

The Cranial SRS Application accepts the following SOP Classes:

SOP Class Name	SOP Class UID	SCU	SCP
Storage			
CT Image	1.2.840.10008.5.1.4.1.1.2	No	Yes
MR Image	1.2.840.10008.5.1.4.1.1.4	No	Yes
PET Image	1.2.840.10008.5.1.4.1.1.128	No	Yes
Volumetric Other			
Segmentation Storage	1.2.840.10008.5.1.4.1.1.66.4	Yes	Yes
Spatial Registration	1.2.840.10008.5.1.4.1.1.66.1	No	Yes
Raw Data Storage	1.2.840.10008.5.1.4.1.1.66	Yes	Yes
Parametric Map	1.2.840.10008.5.1.4.1.1.30	Yes	Yes
RT Dose	1.2.840.10008.5.1.4.1.1.481.2	Yes	No
RT Plan	1.2.840.10008.5.1.4.1.1.481.5	Yes	No
RT Structure Set	1.2.840.10008.5.1.4.1.1.481.3	Yes	No
Other			
Grayscale Softcopy Presentation State	1.2.840.10008.5.1.4.1.1.11.1	No	Yes
Key Object Selection Document Storage	1.2.840.10008.5.1.4.1.1.88.59	Yes	Yes
Query/Retrieve			
Study Root Query/Retrieve Information Model – GET	1.2.840.10008.5.1.4.1.2.2.3	Yes	No

Table 4-13: Cranial SRS Application supported SOP Classes

4.2.4.2 Association Policies

4.2.4.2.1 Implementation Identifying Information

The implementation information for this Application Entity is:

Implementation Class UID	1.2.276.0.20.1.1.106.<version>
Implementation Version Name	DosePlanning<version>

Current possible versions are: <version> = 3.0

4.2.4.3 Association Initiation Policy

The Cranial SRS Application initiates an association in these cases:

- Find Studies, Series and Instances
Initiated to find related studies, series and instances
- Get Studies, Series and Instances
Initiated to retrieve related studies, series and instances
- Save Instances
The user created a new radiotherapy treatment plan.

4.2.4.3.1 Activity – Find Studies, Series and Instances

See Common Specifications, section 4.2.1.3.1.

4.2.4.3.2 Activity – Get Studies, Series and Instances

See Common Specifications, section 4.2.1.3.2, restricted to Study Root Query/Retrieve Information Model – GET and to all SCP Storage SOP Classes and SOP Class UIDs as listed in Table 4-13.

4.2.4.3.3 Activity – Save Instances

4.2.4.3.3.1 Description and Sequencing of Activities

New instances will be created if the user

- Saves a treatment plan. This will be stored as a Key Object Selection Document, Raw Data and Segmentation
- Exports a radiotherapy treatment plan.

4.2.4.3.3.2 Proposed Presentation Contexts

Presentation Context Table			
Abstract Syntax	Transfer Syntax	Role	Ext. Neg
All SCU Storage SOP Classes and SOP Class UIDs as listed in Table 4-13	See Table 4-2 for the SOP Class / Transfer Syntax mapping	SCU	None

Table 4-14: Cranial SRS Application proposed Presentation Contexts – Save Instances

4.2.4.3.3.3 SOP Specific Conformance

The Cranial SRS Application provides standard conformance to the DICOM Storage SOP Classes.

4.2.5 Cranial SRS w/ Cones Application Specification

The Cranial SRS w/ Cones application provides radiation treatment planning for conical collimators. It requests DICOM image, Segmentation, Registration and Raw Data instances from the DICOM Proxy. It creates DICOM RT Structure Set, RT Plan and RT Dose instances and sends these along the image instances to a defined target system.

4.2.5.1 SOP Classes and Transfer Syntaxes

The Cranial SRS w/ Cones Application accepts the following SOP Classes:

SOP Class Name	SOP Class UID	SCU	SCP
Storage			
CT Image	1.2.840.10008.5.1.4.1.1.2	No	Yes
MR Image	1.2.840.10008.5.1.4.1.1.4	No	Yes
PET Image	1.2.840.10008.5.1.4.1.1.128	No	Yes
Volumetric Other			
Segmentation Storage	1.2.840.10008.5.1.4.1.1.66.4	Yes	Yes
Surface Segmentation Storage	1.2.840.10008.5.1.4.1.1.66.5	No	Yes
Spatial Registration	1.2.840.10008.5.1.4.1.1.66.1	No	Yes
Raw Data Storage	1.2.840.10008.5.1.4.1.1.66	Yes	Yes
Parametric Map	1.2.840.10008.5.1.4.1.1.30	Yes	Yes
RT Dose	1.2.840.10008.5.1.4.1.1.481.2	Yes	No
RT Plan	1.2.840.10008.5.1.4.1.1.481.5	Yes	No
RT Structure Set	1.2.840.10008.5.1.4.1.1.481.3	Yes	No
Other			
Grayscale Softcopy Presentation State	1.2.840.10008.5.1.4.1.1.11.1	No	Yes
Key Object Selection Document Storage	1.2.840.10008.5.1.4.1.1.88.59	Yes	Yes
Query/Retrieve			
Study Root Query/Retrieve Information Model – GET	1.2.840.10008.5.1.4.1.2.2.3	Yes	No

Table 4-15: Cranial SRS w/ Cones Application supported SOP Classes

4.2.5.2 Association Policies

4.2.5.2.1 Implementation Identifying Information

The implementation information for this Application Entity is:

Implementation Class UID	1.2.276.0.20.1.1.106.<version>
Implementation Version Name	DosePlanning<version>

Current possible versions are: <version> = 3.0

4.2.5.3 Association Initiation Policy

The Cranial SRS w/ Cones Application initiates an association in these cases:

- Find Studies, Series and Instances
Initiated to find related studies, series and instances
- Get Studies, Series and Instances
Initiated to retrieve related studies, series and instances
- Save Instances
The user created a new radiotherapy treatment plan.

4.2.5.3.1 Activity – Find Studies, Series and Instances

See Common Specifications, section 4.2.1.3.1.

4.2.5.3.2 Activity – Get Studies, Series and Instances

See Common Specifications, section 4.2.1.3.2, restricted to Study Root Query/Retrieve Information Model – GET and to all SCP Storage SOP Classes and SOP Class UIDs as listed in Table 4-17.

4.2.5.3.3 Activity – Save Instances

4.2.5.3.3.1 Description and Sequencing of Activities

New instances will be created if the user

- Saves a treatment plan. This will be stored as a Key Object Selection Document, Raw Data and Segmentation
- Exports a radiotherapy treatment plan.

4.2.5.3.3.2 Proposed Presentation Contexts

Presentation Context Table			
Abstract Syntax	Transfer Syntax	Role	Ext. Neg
All SCU Storage SOP Classes and SOP Class UIDs as listed in Table 4-17	See Table 4-2 for the SOP Class / Transfer Syntax mapping	SCU	None

Table 4-16: Cranial SRS w/ Cones Application proposed Presentation Contexts – Save Instances

4.2.5.3.3.3 SOP Specific Conformance

The Cranial SRS w/ Cones Application provides standard conformance to the DICOM Storage SOP Classes.

4.2.6 Spine SRS Application Specification

The Spine SRS application provides optimized radiation treatment planning for spinal metastases. It requests DICOM image, Segmentation, Registration and Raw Data instances from the DICOM Proxy. It creates DICOM RT Structure Set, RT Plan and RT Dose instances and sends these along the image instances to a defined target system.

4.2.6.1 SOP Classes and Transfer Syntaxes

The Spine SRS Application accepts the following SOP Classes:

SOP Class Name	SOP Class UID	SCU	SCP
Storage			
CT Image	1.2.840.10008.5.1.4.1.1.2	No	Yes
MR Image	1.2.840.10008.5.1.4.1.1.4	No	Yes
PET Image	1.2.840.10008.5.1.4.1.1.128	No	Yes
Volumetric Other			
Segmentation Storage	1.2.840.10008.5.1.4.1.1.66.4	Yes	Yes
Spatial Registration	1.2.840.10008.5.1.4.1.1.66.1	No	Yes
Raw Data Storage	1.2.840.10008.5.1.4.1.1.66	Yes	Yes
Parametric Map	1.2.840.10008.5.1.4.1.1.30	Yes	Yes
RT Dose	1.2.840.10008.5.1.4.1.1.481.2	Yes	No
RT Plan	1.2.840.10008.5.1.4.1.1.481.5	Yes	No
RT Structure Set	1.2.840.10008.5.1.4.1.1.481.3	Yes	No
Other			
Grayscale Softcopy Presentation State	1.2.840.10008.5.1.4.1.1.11.1	No	Yes
Key Object Selection Document Storage	1.2.840.10008.5.1.4.1.1.88.59	Yes	Yes
Query/Retrieve			
Study Root Query/Retrieve Information Model – GET	1.2.840.10008.5.1.4.1.2.2.3	Yes	No

Table 4-17: Spine SRS Application supported SOP Classes

4.2.6.2 Association Policies

4.2.6.2.1 Implementation Identifying Information

The implementation information for this Application Entity is:

Implementation Class UID	1.2.276.0.20.1.1.106.<version>
Implementation Version Name	DosePlanning<version>

Current possible versions are: <version> = 3.0

4.2.6.3 Association Initiation Policy

The Spine SRS Application initiates an association in these cases:

- Find Studies, Series and Instances
Initiated to find related studies, series and instances
- Get Studies, Series and Instances
Initiated to retrieve related studies, series and instances
- Save Instances
The user created a new radiotherapy treatment plan.

4.2.6.3.1 Activity – Find Studies, Series and Instances

See Common Specifications, section 4.2.1.3.1.

4.2.6.3.2 Activity – Get Studies, Series and Instances

See Common Specifications, section 4.2.1.3.2, restricted to Study Root Query/Retrieve Information Model – GET and to all SCP Storage SOP Classes and SOP Class UIDs as listed in Table 4-17.

4.2.6.3.3 Activity – Save Instances

4.2.6.3.3.1 Description and Sequencing of Activities

New instances will be created if the user

- Saves a treatment plan. This will be stored as a Key Object Selection Document, Raw Data and Segmentation
- Export a radiotherapy treatment plan the user requests storage of this plan.

4.2.6.3.3.2 Proposed Presentation Contexts

Presentation Context Table			
Abstract Syntax	Transfer Syntax	Role	Ext. Neg
All SCU Storage SOP Classes and SOP Class UIDs as listed in Table 4-17	See Table 4-2 for the SOP Class / Transfer Syntax mapping	SCU	None

Table 4-18: Spine SRS Application proposed Presentation Contexts – Save Instances

4.2.6.3.3.3 SOP Specific Conformance

The Spine SRS Application provides standard conformance to the DICOM Storage SOP Classes.

4.2.7 Dose Review Application Specification

The Dose Review application contains features for review of isodose lines, review of DVHs, dose comparison and summation. It requests DICOM image, Registration, Segmentation and . It does not create any new DICOM instances.

4.2.7.1 SOP Classes and Transfer Syntaxes

The Dose Review Application accepts the following SOP Classes:

SOP Class Name	SOP Class UID	SCU	SCP
Storage			
CT Image	1.2.840.10008.5.1.4.1.1.2	No	Yes
MR Image	1.2.840.10008.5.1.4.1.1.4	No	Yes
PET Image	1.2.840.10008.5.1.4.1.1.128	No	Yes
Volumetric Other			
Segmentation Storage	1.2.840.10008.5.1.4.1.1.66.4	No	Yes
Spatial Registration	1.2.840.10008.5.1.4.1.1.66.1	No	Yes
Raw Data Storage	1.2.840.10008.5.1.4.1.1.66	No	Yes
Parametric Map	1.2.840.10008.5.1.4.1.1.30	No	Yes
Other			
Grayscale Softcopy Presentation State	1.2.840.10008.5.1.4.1.1.11.1	No	Yes
Key Object Selection Document Storage	1.2.840.10008.5.1.4.1.1.88.59	No	Yes
Query/Retrieve			
Study Root Query/Retrieve Information Model – GET	1.2.840.10008.5.1.4.1.2.2.3	Yes	No

Table 4-19: Dose Review Application supported SOP Classes

4.2.7.2 Association Policies

4.2.7.2.1 Implementation Identifying Information

The implementation information for this Application Entity is:

Implementation Class UID	1.2.276.0.20.1.1.106.<version>
Implementation Version Name	DosePlanning<version>

Current possible versions are: <version> = 3.0
For version 1.0 see [4].

4.2.7.3 Association Initiation Policy

The Dose Review Application initiates an association in these cases:

- Find Studies, Series and Instances
Initiated to find related studies, series and instances

- Get Studies, Series and Instances
Initiated to retrieve related studies, series and instances

4.2.7.3.1 Activity – Find Studies, Series and Instances

See Common Specifications, section 4.2.1.3.1.

4.2.7.3.2 Activity – Get Studies, Series and Instances

See Common Specifications, section 4.2.1.3.2, restricted to Study Root Query/Retrieve Information Model – GET and to all SCP Storage SOP Classes and SOP Class UIDs as listed in Table 4-19.

4.2.8 RT QA Application Specification

The RT QA application provides means for verification of beam models as well as patient specific quality assurance. It requests DICOM image, Segmentation, Registration and Raw Data instances from the DICOM Proxy. It creates DICOM RT Structure Set, RT Plan and RT Dose instances and sends these along the image instances to a defined target system.

4.2.8.1 SOP Classes and Transfer Syntaxes

The RT QA Application accepts the following SOP Classes:

SOP Class Name	SOP Class UID	SCU	SCP
Storage			
CT Image	1.2.840.10008.5.1.4.1.1.2	No	Yes
MR Image	1.2.840.10008.5.1.4.1.1.4	No	Yes
PET Image	1.2.840.10008.5.1.4.1.1.128	No	Yes
Volumetric Other			
Spatial Registration	1.2.840.10008.5.1.4.1.1.66.1	No	Yes
Segmentation Storage	1.2.840.10008.5.1.4.1.1.66.4	Yes	Yes
Raw Data Storage	1.2.840.10008.5.1.4.1.1.66	Yes	Yes
Parametric Map	1.2.840.10008.5.1.4.1.1.30	Yes	Yes
RT Dose	1.2.840.10008.5.1.4.1.1.481.2	Yes	No
RT Plan	1.2.840.10008.5.1.4.1.1.481.5	Yes	No
RT Structure Set	1.2.840.10008.5.1.4.1.1.481.3	Yes	No
Other			
Grayscale Softcopy Presentation State	1.2.840.10008.5.1.4.1.1.11.1	No	Yes
Key Object Selection Document Storage	1.2.840.10008.5.1.4.1.1.88.59	Yes	Yes
Query/Retrieve			
Study Root Query/Retrieve Information Model – GET	1.2.840.10008.5.1.4.1.2.2.3	Yes	No

Table 4-20: RT QA Application supported SOP Classes

4.2.8.2 Association Policies

4.2.8.2.1 Implementation Identifying Information

The implementation information for this Application Entity is:

Implementation Class UID	1.2.276.0.20.1.1.106.<version>
Implementation Version Name	DosePlanning<version>

Current possible versions are: <version> = 3.0

4.2.8.3 Association Initiation Policy

The RT QA Application initiates an association in these cases:

- Find Studies, Series and Instances
Initiated to find related studies, series and instances
- Get Studies, Series and Instances
Initiated to retrieve related studies, series and instances
- Save Instances
The user created a new radiotherapy treatment plan.

4.2.8.3.1 Activity – Find Studies, Series and Instances

See Common Specifications, section 4.2.1.3.1.

4.2.8.3.2 Activity – Get Studies, Series and Instances

See Common Specifications, section 4.2.1.3.2, restricted to Study Root Query/Retrieve Information Model – GET and to all SCP Storage SOP Classes and SOP Class UIDs as listed in Table 4-20.

4.2.8.3.3 Activity – Save Instances

4.2.8.3.3.1 Description and Sequencing of Activities

New instances will be created if the user

- Saves a treatment plan. This will be stored as a Key Object Selection Document, Raw Data and Segmentation
- Exports a radiotherapy treatment plan.

4.2.8.3.3.2 Proposed Presentation Contexts

Presentation Context Table			
Abstract Syntax	Transfer Syntax	Role	Ext. Neg
All SCU Storage SOP Classes and SOP Class UIDs as listed in Table 4-20	See Table 4-2 for the SOP Class / Transfer Syntax mapping	SCU	None

Table 4-21: RT QA Application proposed Presentation Contexts – Save Instances

4.2.8.3.3.3 SOP Specific Conformance

The RT QA Application provides standard conformance to the DICOM Storage SOP Classes.

4.2.9 DICOM RT Export Performer Specification

The DICOM RT Export Performer allows conversion of 3D objects and registration (fusion) data to DICOM RT compliant format.

4.2.9.1 SOP Classes and Transfer Syntaxes

The DICOM RT Export Performer accepts the following SOP Classes:

SOP Class Name	SOP Class UID	SCU	SCP
Storage			
All Image Storage SOP Classes and associated SOP Class UIDs as listed in Table 4-2		Yes	Yes
Grayscale Softcopy Presentation State	1.2.840.10008.5.1.4.1.1.11.1	Yes	Yes
Key Object Selection Document	1.2.840.10008.5.1.4.1.1.88.59	No	Yes
Raw Data Storage	1.2.840.10008.5.1.4.1.1.66	Yes	Yes
RT Structure Set	1.2.840.10008.5.1.4.1.1.481.3	Yes	No
Segmentation Storage	1.2.840.10008.5.1.4.1.1.66.4	No	Yes
Spatial Fiducials Storage	1.2.840.10008.5.1.4.1.1.66.2	Yes	Yes
Spatial Registration	1.2.840.10008.5.1.4.1.1.66.1	Yes	Yes
Surface Segmentation Storage	1.2.840.10008.5.1.4.1.1.66.5	Yes	Yes
Query/Retrieve			
Study Root Query/Retrieve Information Model – GET	1.2.840.10008.5.1.4.1.2.2.3	Yes	No

Table 4-22: DICOM RT Export Performer supported SOP Classes

4.2.9.2 Association Policies

4.2.9.2.1 Implementation Identifying Information

The implementation information for this Application Entity is:

Implementation Class UID	1.2.276.0.20.1.1.39.<version>
Implementation Version Name	RTEExport<version>

Current possible versions are: <version> = 2.1

4.2.9.3 Association Initiation Policy

The DICOM RT Export Performer initiates an association in these cases:

- Find Studies, Series and Instances
Initiated to find related studies, series and instances
- Get Studies, Series and Instances
Initiated to retrieve related studies, series and instances
- Save Instances:
The application converted Segmentation instances.

4.2.9.3.1 Activity – Find Studies, Series and Instances

See Common Specifications, section 4.2.1.3.1.

4.2.9.3.2 Activity – Get Studies, Series and Instances

See Common Specifications, section 4.2.1.3.2, restricted to Study Root Query/Retrieve Information Model – GET and to all SCP Storage SOP Classes and SOP Class UIDs as listed in Table 4-22.

4.2.9.3.3 Activity – Save Instances

4.2.9.3.3.1 Description and Sequencing of Activities

After successful segmentation a number of storage requests is performed to send the newly created RT Structure Set and image data instances to a pre-defined DICOM Push Target.

4.2.9.3.3.2 Proposed Presentation Contexts

Presentation Context Table			
Abstract Syntax	Transfer Syntax	Role	Ext. Neg
All SCU Storage SOP Classes and SOP Class UIDs as listed in Table 4-22	See Table 4-2 for the SOP Class / Transfer Syntax mapping	SCU	None

Table 4-23: DICOM RT Export Performer proposed Presentation Contexts – Save Instances

4.2.9.3.3.3 SOP Specific Conformance

The DICOM RT Export Performer provides standard conformance to the DICOM Storage SOP Classes.

4.2.10 DICOM RT Import Performer Specification

The DICOM RT Import Performer allows conversion of DICOM RT Structure Sets, DICOM RT Plans and DICOM RT Dose to the internal format. See 4.4.1 for configuration.

4.2.10.1 SOP Classes and Transfer Syntaxes

The DICOM RT Import Performer accepts the following SOP Classes:

SOP Class Name	SOP Class UID	SCU	SCP
Storage			
All Image Storage SOP Classes and associated SOP Class UIDs as listed in Table 4-2		No	Yes
Key Object Selection Document	1.2.840.10008.5.1.4.1.1.88.59	Yes	No
Raw Data Storage	1.2.840.10008.5.1.4.1.1.66	Yes	No
Parametric Map	1.2.840.10008.5.1.4.1.1.30	Yes	No
RT Dose	1.2.840.10008.5.1.4.1.1.481.2	Yes ³	No
RT Plan	1.2.840.10008.5.1.4.1.1.481.5	No	Yes
RT Structure Set	1.2.840.10008.5.1.4.1.1.481.3	No	Yes

³ The import of DICOM RT Dose instances is disabled by default and should only be activated for applications capable of loading imported dose volumes.

SOP Class Name	SOP Class UID	SCU	SCP
Storage			
Segmentation Storage	1.2.840.10008.5.1.4.1.1.66.4	Yes	No
Query/Retrieve			
Study Root Query/Retrieve Information Model – GET	1.2.840.10008.5.1.4.1.2.2.3	Yes	No

Table 4-24: DICOM RT Import Performer supported SOP Classes

4.2.10.2 Association Policies

4.2.10.2.1 Implementation Identifying Information

The implementation information for this Application Entity is:

Implementation Class UID	1.2.276.0.20.1.1.92.<version>
Implementation Version Name	RTImportPerformer

Current possible versions are: <version> = 3.0

4.2.10.3 Association Initiation Policy

The DICOM RT Import Performer initiates an association in these cases:

- Find Studies, Series and Instances
Initiated to find related studies, series and instances
- Get Studies, Series and Instances
Initiated to retrieve related studies, series and instances
- Save Instances:
The application converted Segmentation, Raw Data Storage and Key Object Selection instances.

4.2.10.3.1 Activity – Find Studies, Series and Instances

See Common Specifications, section 4.2.1.3.1.

4.2.10.3.2 Activity – Get Studies, Series and Instances

See Common Specifications, section 4.2.1.3.2, restricted to Study Root Query/Retrieve Information Model – GET and to all SCP Storage SOP Classes and SOP Class UIDs as listed in Table 4-22.

4.2.10.3.3 Activity – Save Instances

4.2.10.3.3.1 Description and Sequencing of Activities

After successful import, Segmentation, Raw Data Storage, Parametric Map and Key Object Selection instances are stored to the DICOM Proxy.

4.2.10.3.3.2 Proposed Presentation Contexts

Presentation Context Table			
Abstract Syntax	Transfer Syntax	Role	Ext. Neg
All SCU Storage SOP Classes and SOP Class UIDs as listed in Table 4-22	See Table 4-2 for the SOP Class / Transfer Syntax mapping	SCU	None

Table 4-25: DICOM RT Import Performer proposed Presentation Contexts – Save Instances

4.2.10.3.3.3 SOP Specific Conformance

The DICOM RT Import Performer provides standard conformance to the DICOM Storage SOP Classes.

4.3 Network Interfaces

4.3.1 Physical Network Interface

The applications and performers support the DICOM upper layer using TCP/IP and are indifferent to the physical medium over which TCP/IP executes. The applications and performers inherit this from the operating system upon which they are executed.

4.3.2 Additional Protocols

The usage of DNS and DHCP is possible and is based on the network configuration of the operating system upon which the applications and performers execute.

4.4 Configuration

4.4.1 AE Title

In addition to the AE Title as described in [2], the DICOM RT Import Performer provides an additional AET on which the import of DICOM RT data will be triggered.

Application Entity	Default AE Title	Default TCP/IP Port
DICOM Proxy	BL_IMPORT	104

Only if DICOM RT data is actively pushed to this AET the actual conversion into the Brainlab internal format will be performed. Retrieving DICOM RT data using Query/Retrieve will not trigger the DICOM RT Import Performer.

5 Media Interchange

5.1 Implementation Model

5.1.1 Application Data Flow Diagram

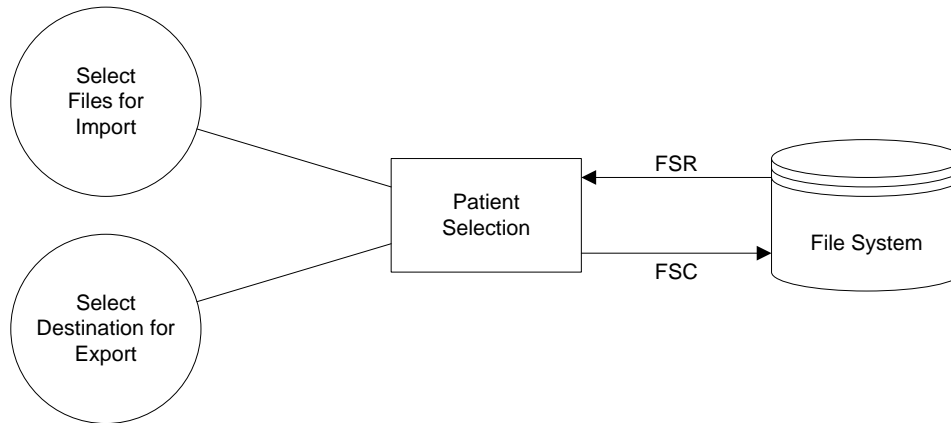

Figure 5-1: The Patient Selection Data Flow Diagram

5.1.2 Functional Definitions of AE's

5.1.2.1 Functional Definition of Patient Selection

- Import:
The Patient Selection allows the user to select a DICOM medium, e.g. a CD, a DVD or a folder in the file system. If the medium contains a DICOMDIR it is evaluated and all indexed instances will be scanned and presented to the user.
If there is no DICOMDIR, the application will scan the files beneath the selected folder and will present to the user all DICOM instances that are supported and valid.
Finally the user can select one or more series and start the upload.
Note: The DICOM RT Import Performer will not be triggered when a DICOM medium is selected in the Patient Selection.

5.1.3 Sequencing of Real-World Activities

Not necessary.

5.1.4 File Meta Information Options

See in 5.2 AE Specifications.

5.2 AE Specifications

5.2.1 Common Export Specifications

This section contains the specifications valid for all application entities supporting media interchange in this Conformance Statement. In successive application entity sections only the differences or additional information will be described.

Affected applications provide standard conformance to the Media Storage Service Class. The application profiles and roles are listed below:

AE Related Application Profiles, Real-World Activities, and Roles			
Supported APs	Real World Activity	Roles	Options
BL-PRV-GEN	Export	FSC	No DICOMDIR

Table 5-1: Multiple Brain Mets SRS supported Media Interchange Profiles.

5.2.1.1 File Meta Information for the Application Entity

The Source Application Entity Title included in the File Meta Header is configurable.

5.2.1.2 Real World Activities

5.2.1.2.1 Activity – Export

The Multiple Brain Mets SRS, Cranial SRS, Spine SRS and RT QA application allow to export the current plan to a file system. The user can select an export platform which defines the DICOM IODs to export and some destination specific settings. According to the export platform the DICOM IODs are created and saved to the file system destination defined by the export platform.

5.2.1.2.1.1 Media Storage Application Profiles

The Patient Selection supports the BL-PRV-GEN Application Profile File System Reader.

5.2.1.2.1.1.1 Option - Supported SOP Classes and Transfer Syntaxes

SOP Class Name	SOP Class UID	Transfer Syntax	Transfer Syntax UID
All SOP Classes from Table 4-2		All transfer syntaxes from Table 4-1	

Table 5-2: Patient Selection supported SOP Classes and Transfer Syntaxes

5.2.1.2.1.1.2 Option - Physical Medium and Medium Format

The Patient Selection supports reading the PC File System (see [3] PS 3.12, Annex A).

5.2.1.2.1.1.3 Option - Basic Directory

The Patient Selection supports evaluating a DICOMDIR.

5.3 Augmented and Private Application Profiles

5.3.1 Augmented Application Profiles

None.

5.3.2 Private Application Profiles

5.3.2.1 Brainlab Export Profiles

5.3.2.1.1 Profile Identification

This section defines an Application Profile Class potentially inclusive of all defined Media Storage SOP Classes. This class is intended to be used for the export of Composite SOP Instances via the file system. Objects from multiple modalities may be included on the same media.

See Table 4-2 for a detailed list of supported Media Storage SOP Classes.

Application Profile	Identifier	Description
Brainlab RT 1 st Generation Export to File System	BL-EXPORT-RT1STGEN-1	Handles export of planned RT data with RT 1 st Generation DICOM IODs.

Table 5-3: Brainlab BL-EXPORT Profiles.

5.3.2.1.2 Clinical Context

This Application Profile facilitates the export of any DICOM Composite Instance to any non-Brainlab system expecting DICOM media files as input.

5.3.2.1.2.1 Roles and Service Class Options

This Application Profile uses the Media Storage Service Class defined in PS3.4.

The Application Entity shall support the role of the File Set Creator (FSC) as defined in [3] PS 3.10.

5.3.2.1.2.1.1 File Set Creator

The application entity acting as a File-Set Creator generates a File Set under a BL-EXPORT-Application Profile. The File Set Creator doesn't generate a DICOMDIR file.

For each export the File Set Creator shall create a unique directory beneath the export destination which then contains all exported DICOM media files.

5.3.2.1.3 BL-EXPORT Profiles

5.3.2.1.3.1 SOP Classes and Transfer Syntaxes

This Application Profile is based on the Media Storage Service Class (see [3] PS 3.4).

IOD	SOP Class UID	Transfer Syntax	Profiles	FSC
CT Image Storage	1.2.840.10008.5.1.4.1.1.2		BL-EXPORT-RT1STGEN-1	Mandatory

IOD	SOP Class UID	Transfer Syntax	Profiles	FSC
MR Image Storage	1.2.840.10008.5.1.4.1.1.4	See Table 4-2 for the SOP Class / Transfer Syntax mapping	BL-EXPORT-RT1STGEN-1	Mandatory
RT Dose Storage	1.2.840.10008.5.1.4.1.1.481.2		BL-EXPORT-RT1STGEN-1	Mandatory
RT Plan Storage	1.2.840.10008.5.1.4.1.1.481.5		BL-EXPORT-RT1STGEN-1	Mandatory
RT Structure Set Storage	1.2.840.10008.5.1.4.1.1.481.3		BL-EXPORT-RT1STGEN-1	Mandatory
Spatial Registration Storage	1.2.840.10008.5.1.4.1.1.66.1		BL-EXPORT-RT1STGEN-1	Mandatory

Table 5-4: BL-RT-EXPORT SOP Classes and Transfer Syntaxes.

Note: For the Composite Instance Storage at least one of FSC, FSR or FSU must be supported to fulfill this profile.

5.3.2.1.4 Physical Medium and Medium Format

BL-PRV-GEN requires either the PC File System (see [3] PS 3.12, Annex A) or the ZIP File Media (see [3] PS 3.12, Annex V).

Furthermore this profile supports all media like CD, DVD, USB, CF, MMC or SD which seamlessly integrates into the OS file system for reading, writing and updating. It also supports filenames not fulfilling the 8 + 3 rule of the above mentioned PC File System.

5.3.2.1.5 Directory Information in DICOMDIR

Conformant Application Entities may include in the DICOMDIR File the Basic Directory IOD containing Directory Records at the Patient and the subsidiary Study and Series levels, appropriate to the SOP Classes in the File Set.

All DICOM files in the File Set incorporating SOP Instances defined for the specific Application Profile shall be referenced by Directory Records.

All implementations shall include the DICOM Media Storage Directory in the DICOMDIR file. There shall be exactly one or no DICOMDIR file per File Set. The DICOMDIR file shall be in the root directory of the medium.

The Patient ID at the patient level shall be unique for each patient directory record in one File Set.

If there is no DICOMDIR this profile allows recursive scanning of file systems for DICOM instances.

Whether the DICOMDIR is supported and how a file system scan is performed needs to be described in the Conformance Statement.

5.3.2.1.6 Additional Keys

File Set Creators and Updaters are required to generate the mandatory elements specified in [3] PS 3.3.

5.3.2.1.7 Other Parameters

Not applicable.

5.3.2.1.8 Security Parameters

Not applicable.

6 Support of Character Sets

The applications and performers in common support the following character sets:

- ISO_IR 100 (ISO 8859-1; Latin Alphabet No. 1: Western European)

Character Sets	RT Preparation	Multiple Brain Mets SRS	Cranial SRS	Cranial SRS w/ Cones	Spine SRS	Dose Review	RT QA	DICOM RT Export	DICOM RT Import
ISO_IR 100	●	●	●	●	●	●	●	●	●

Table 6-1: Application and performer specific supported character sets

For supported character sets of other applications, refer to [1].

7 Security Profiles

7.1 Security Profiles

None supported

7.2 Association Level Security

None supported.

7.3 Application Level Security

None supported

8 Annexes

8.1 IOD Contents

8.1.1 Supported SOP Instances

8.1.1.1 Secondary Capture Image

See [1].

8.1.1.2 Grayscale Presentation State

See [1].

8.1.1.3 Standard RT Structure Set

IE	Module	Reference	Support
Patient	Patient	8.1.2.1.1	
	Clinical Trial Subject		Not supported
Study	General Study	8.1.2.1.2	
	Patient Study	8.1.2.1.3	
	Clinical Trial Study		Not supported
Series	RT Series	8.1.2.3.1	
	Clinical Trial Series		Not supported
Frame of Reference	Frame of Reference	8.1.2.1.5	
Equipment	General Equipment	8.1.2.1.6	
Structure Set	Structure Set	8.1.2.3.5	
	ROI Contour	8.1.2.3.6	
	RT ROI Observations	8.1.2.3.7	
	Approval	8.1.2.3.8	Import only
	Common Instance Reference	8.1.2.2.2	
	SOP Common	8.1.2.2.1	

Table 8-1: RT Structure Set Storage IOD

8.1.1.4 Standard RT Plan

IE	Module	Reference	Support
Patient	Patient	8.1.2.1.1	
	Clinical Trial Subject		Not supported
Study	General Study	8.1.2.1.2	
	Patient Study	8.1.2.1.3	
	Clinical Trial Study		Not supported
Series	RT Series	8.1.2.3.1	
	Clinical Trial Series		Not supported
Frame of Reference	Frame of Reference	8.1.2.1.5	
Equipment	General Equipment	8.1.2.1.6	
Plan	RT General Plan	8.1.2.3.9	

IE	Module	Reference	Support
	RT Prescription	8.1.2.3.6	
	RT Tolerance Tables	8.1.2.3.11	
	RT Patient Setup	8.1.2.3.12	
	RT Fraction Scheme	8.1.2.3.13	
	RT Beams	8.1.2.3.7	
	RT Brachy Application Setups		Not supported
	Approval	8.1.2.3.8	
	Common Instance Reference	8.1.2.2.2	
	SOP Common	8.1.2.2.1	
Extended Interface	Extended Interface	8.2.4	Not always present

Table 8-2: RT Plan Storage IOD

8.1.1.5 Standard RT Dose

IE	Module	Reference	Support
Patient	Patient	8.1.2.1.1	
	Clinical Trial Subject		Not supported
Study	General Study	8.1.2.1.2	
	Patient Study	8.1.2.1.3	
	Clinical Trial Study		Not supported
Series	RT Series	8.1.2.3.1	
	Clinical Trial Series		Not supported
Frame of Reference	Frame of Reference	8.1.2.1.5	
Equipment	General Equipment	8.1.2.1.6	
Dose	General Image	8.1.2.1.7	
	Image Plane	8.1.2.1.9	
	Image Pixel	8.1.2.3.4	
	Multi-Frame	8.1.2.1.10	
	Overlay Plane		Not supported
	Multi-Frame Overlay		Not supported
	Modality LUT		Not supported
	RT Dose	8.1.2.3.16	
	RT DVH	8.1.2.3.17	Not always present
	Structure Set		Not supported
	ROI Contour	8.1.2.3.6	Not supported
	RT Dose ROI	8.1.2.3.7	Not supported
	Common Instance Reference	8.1.2.2.2	
	SOP Common	8.1.2.2.1	
Frame Extraction		Not supported	

Table 8-3: RT Dose Storage IOD

8.1.1.6 Structured Report Documents

See [1].

8.1.1.7 Spatial Registration

See [1].

8.1.1.8 Segmentation

See [1].

8.1.1.9 Surface Segmentation

See [1].

8.1.1.10 Raw Data

See [1].

8.1.2 Supported Modules

8.1.2.1 Common Composite Image Modules

8.1.2.1.1 Patient

Attribute Name	Tag	VR	Import	Export
Patient's Name	(0010,0010)	PN	Used to identify the patient (see 8.1.3.3)	
Patient ID	(0010,0020)	LO	Used to identify the patient (see 8.1.3.3)	
Patient's Birth Date	(0010,0030)	DA	Used to identify the patient (see 8.1.3.3)	
Patient's Sex	(0010,0040)	CS		

Table 8-4: Patient Module

8.1.2.1.2 General Study

Attribute Name	Tag	VR	Import	Exported
Study Instance UID	(0020,000D)	UI		
Study Date	(0008,0020)	DA		Generated for new studies with <CurrentDate>; otherwise as imported
Referring Physician's Name	(0008,0090)	PN		EMPTY for new studies; otherwise as imported
Study ID	(0020,0010)	SH		
Accession Number	(0008,0050)	SH		EMPTY for new studies; otherwise as imported
Study Description	(0008,1030)	LO		Generated for new studies; otherwise as imported

Table 8-5: General Study Module

8.1.2.1.3 Patient Study

Attribute Name	Tag	VR	Import	Exported
Patient's Height	(0010,1020)	DS		
Patient's Weight	(0010,1030)	DS		

Table 8-6: Patient Study Module
8.1.2.1.4 General Series

Attribute Name	Tag	VR	Import	Export
Modality	(0008,0060)	CS		
Series Instance UID	(0020,000E)	UI		Generated for new series; otherwise as imported
Series Number	(0020,0011)	IS		Generated for new series; otherwise as imported
Series Date	(0008,0021)	DA		Generated with <Creation Date> for new series; otherwise as imported
Series Time	(0008,0031)	TM		Generated with <Creation Time> for new series; otherwise as imported
Series Description	(0008,103E)	LO		Generated for new series; otherwise as imported
Patient Position	(0018,5100)	DA		Written for any Image IOD if data originated from either one of CT, MR, XA or CR regarding the attribute (0008, 0060) Modality.

Table 8-7: General Series Module
8.1.2.1.5 Frame Of Reference

Attribute Name	Tag	VR	Import	Export
Frame of Reference UID	(0020,0052)	UI		
Position Reference Indicator	(0020,1040)	LO		

Table 8-8: Frame of Reference Module

Note: See section 8.1.3.4 for the usage of the Frame of Reference in Brainlab applications and performers.

8.1.2.1.6 (Enhanced) General Equipment

Attribute Name	Tag	VR	Import	Export
Manufacturer	(0008,0070)	LO		"Brainlab"
Manufacturer's Model Name	(0008,1090)	LO		<ApplicationName>
Device Serial Number	(0008,1000)	SH		<HostID> or <Serial Number>
Software Version(s)	(0018,1020)	LO		<ApplicationVersion>

Table 8-9: (Enhanced) General Equipment Module
8.1.2.1.7 General Image

Attribute Name	Tag	VR	Import	Export
Instance Number	(0020,0013)	IS		

Content Date	(0008,0023)	DA		<Current Date>
Content Time	(0008,0033)	TM		<Current Time>

Table 8-10: General Image Module

8.1.2.1.8 Image Pixel

Attribute Name	Tag	VR	Import	Export
Samples per Pixel	(0028,0002)	US	See 8.1.3.1.1	
Photometric Interpretation	(0028,0004)	CS	See 8.1.3.1.1	
Rows	(0028,0010)	IS		
Columns	(0028,0011)	DA	See 8.1.3.2 for Segmentation IODs Otherwise: no limitation	
Bits Allocated	(0028,0100)	US	See 8.1.3.1.1	
Bits Stored	(0028,0101)	US		
High Bit	(0028,0102)	US		
Pixel Representation	(0028,0103)	US		
Planar Configuration	(0028,0006)	US		
Pixel Data	(7FE0,0010)	OW		

Table 8-11: Image Pixel Module

8.1.2.1.9 Image Plane

Attribute Name	Tag	VR	Import	Export
Pixel Spacing	(0028,0030)	DS		
Image Orientation (Patient)	(0020,0037)	DS		
Image Position (Patient)	(0020,0032)	DS		
Slice Thickness	(0018,0050)	DS		

Table 8-12: Image Plane Module

8.1.2.1.10 Multi-frame

Attribute Name	Tag	VR	Import	Export
Number of Frames	(0028,0008)	US		
Frame Increment Pointer	(0028,0009)	AT		For SC Image IOD it points to (0018,2002) Frame Label Vector

Table 8-13: Multi-frame Module

8.1.2.2 General Modules

8.1.2.2.1 SOP Common Module

Attribute Name	Tag	VR	Import	Export
SOP Class UID	(0008,0016)	DS		IOD specific
SOP Instance UID	(0008,0018)	DS		Generated

Specific Character Set	(0008,0005)	CS		"ISO_IR 100"
Instance Creation Date	(0008,0012)	DA		<Current Date>
Instance Creation Time	(0008,0013)	TM		<Current Time>

Table 8-14: SOP Common Module

8.1.2.2.2 Common Instance Reference Module

Attribute Name	Tag	VR	Import	Export
Referenced Series Sequence	(0008,1115)	SQ		
>Series Instance UID	(0020,000E)	UI		
>Referenced Instance Sequence	(0008,114A)	SQ		
>>Referenced SOP Class UID	(0008,1150)	UI		
>>Referenced SOP Instance UID	(0008,1155)	UI		
Studies Containing Other Referenced Instances Sequence	(0008,1200)	SQ		
>Study Instance UID	(0020,000D)	UI		
>Referenced Series Sequence	(0008,1115)	SQ		
>>Series Instance UID	(0020,000E)	UI		
>>Referenced Instance Sequence	(0008,114A)	SQ		
>>>Referenced SOP Class UID	(0008,1150)	UI		
>>>Referenced SOP Instance UID	(0008,1155)	UI		

Table 8-15: Common Instance Reference Module

8.1.2.3 RT Modules

8.1.2.3.1 RT Series Module

Attribute Name	Tag	VR	Import	Export
Modality	(0008,0060)	CS	RTSTRUCT, RTPLAN, RTDOSE	RTSTRUCT, RTPLAN, RTDOSE
Series Instance UID	(0020,000E)	UI		
Series Number	(0020,0011)	IS		

Table 8-16: RT Series Module

8.1.2.3.2 General Image (RT Dose)

Attribute Name	Tag	VR	Import	Export
Instance Number	(0020,0013)	IS		
Content Date	(0008,0023)	DA		
Content Time	(0008,0033)	TM		
Image Type	(0008,0008)	CS		DERIVED\SECONDARY

Table 8-17: General Image Module (RT Dose)

8.1.2.3.3 General Image (RTQA Application, Patient Verification Mode)

Attribute Name	Tag	VR	Import	Export
Instance Number	(0020,0013)	IS		
Content Date	(0008,0023)	DA		
Content Time	(0008,0033)	TM		
Image Type	(0008,0008)	CS		DERIVED\SECONDARY
Quality Control Image	(0028,0300)	CS		YES

Table 8-18: General Image Module

8.1.2.3.4 Image Pixel Module (RT Dose)

Attribute Name	Tag	VR	Import	Export
Samples per Pixel	(0028,0002)	US		
Photometric Interpretation	(0028,0004)	CS		
Rows	(0028,0010)	IS		
Columns	(0028,0011)	DA		
Bits Allocated	(0028,0100)	US	"16" or "32"	"16" or "32"
Bits Stored	(0028,0101)	US	"16" or "32"	"16" or "32"
High Bit	(0028,0102)	US	"15" or "31"	"15" or "31"
Pixel Representation	(0028,0103)	US		
Planar Configuration	(0028,0006)	US		
Pixel Data	(7FE0,0010)	OW		

Table 8-19: Image Pixel Module (RT Dose)

8.1.2.3.5 Structure Set Module

Attribute Name	Tag	VR	Import	Export
Structure Set Label	(3006,0002)	SH	ID of imported Plan, if no referencing RT Plan was available.	
Structure Set Name	(3006,0004)	LO	Name of imported Plan, if no referencing RT Plan was available.	
Structure Set Description	(3006,0006)	ST		
Instance Number	(0020,0013)	IS		
Structure Set Date	(3006,0008)	DA	Date of imported Plan, if no referencing RT Plan was available.	
Structure Set Time	(3006,0009)	TM	Time of imported Plan, if no referencing RT Plan was available.	
Referenced Frame of Reference Sequence	(3006,0010)	SQ	Only one Item is supported.	Only one Item is supported.
>Frame of Reference UID	(0020,0052)	UI		
>Frame of Reference Relationship Sequence	(3006,00C0)	SQ	Not evaluated.	Not supported.

>RT Referenced Study Sequence	(3006,0012)	SQ		
>>Referenced SOP Class UID	(0008,1150)	UI		
>>Referenced SOP Instance UID	(0008,1155)	UI		
>>RT Referenced Series Sequence	(3006,0014)	SQ		
>>Series Instance UID	(0020,000E)	UI		
>>>Contour Image Sequence	(3006,0016)	SQ		
>>>>Referenced SOP Class UID	(0008,1150)	UI		
>>>>Referenced SOP Instance UID	(0008,1155)	UI		
Structure Set ROI Sequence	(3006,0020)	SQ		
>ROI Number	(3006,0022)	IS	See ⁴	
>Referenced Frame of Reference UID	(3006,0024)	UI		
>ROI Name	(3006,0026)	LO		
>ROI Volume	(3006,002C)	DS		
>ROI Generation Algorithm	(3006,0038)	CS		

Table 8-20: Structure Set Module

8.1.2.3.6 ROI Contour Module

Attribute Name	Tag	VR	Import	Export
ROI Contour Sequence	(3006,0039)	SQ		
>Referenced ROI Number	(3006,0084)	IS		
>ROI Display Color	(3006,002A)	IS		
>Contour Sequence	(3006,0040)	SQ		
>>Contour Number	(3006,0048)	IS		
>>Contour Image Sequence	(3006,0016)	SQ		
>>>Referenced SOP Class UID	(0008,1150)	UI		
>>>Referenced SOP Instance UID	(0008,1155)	UI		
>>Contour Geometric Type	(3006,0042)	CS	"CLOSED_PLANAR" only	"CLOSED_PLANAR" and "POINT"
>>Contour Offset Vector	(3006,0045)	DS	If present, expected to be zero. Otherwise ROI will not be imported.	Not present.
>>Number of Contour Points	(3006,0046)	IS	Expected to be consistent with Contour Data (3006,0050).	

⁴ The ROI Number is expected to be present in the Structure Set ROI Sequence (3006,0020) and referenced accordingly within the ROI Contour Sequence (3006,0039) and the RT ROI Observations Sequence (3006,0080). Otherwise the ROI will not be imported as it is not considered to be fully defined.

>>Contour Data	(3006,0050)	DS	Z-value of Contour Data points have to be within 0.01mm of referenced image plane.	See 5.
----------------	-------------	----	--	--------

Table 8-21: ROI Contour Module

8.1.2.3.7 ROI Observations Module

Attribute Name	Tag	VR	Import	Export
RT ROI Observations Sequence	(3006,0080)	SQ		
>Observation Number	(3006,0082)	IS		
>Referenced ROI Number	(3006,0084)	IS		
>RT ROI Interpreted Type	(3006,00A4)	CS	“EXTERNAL”, “PTV”, “CTV”, “GTV”, “AVOIDANCE”, “SUPPORT”. See ⁶	“EXTERNAL”, “CTV”, “GTV”, “PTV”, “AVOIDANCE”, “ORGAN”, “SUPPORT”, “ISOCENTER”
>ROI Interpreter	(3006,00A6)	PN		

Table 8-22: RT ROI Observations Module

8.1.2.3.8 Approval Module

Attribute Name	Tag	VR	Import	Export
Approval Status	(300E,0002)	CS	Approval state of imported Plan.	“UNAPPROVED”, “APPROVED”, “REJECTED”
Review Date	(300E,0004)	DA	Approval date of imported Plan.	
Review Time	(300E,0005)	TM	Approval time of imported Plan.	
Reviewer Name	(300R,0008)	PN	Approver of imported Plan.	

Table 8-23: Approval Module

⁵ According to the definition of the transfer syntax or the capabilities of third-party systems there is a maximum number of contour points. As the contours are created with a very high resolution it might be possible that this maximum number of contour points may be reached and thus a reduction of precision will take place.

⁶ In case the RT ROI Interpreted Type (3006,00A6) contradicts with the specification of the Dose Reference Type (300A,0020) of the RT Plan, then the definition within the Dose Reference Sequence will override the RT ROI Interpreted Type.

8.1.2.3.9 RT General Plan Module

Attribute Name	Tag	VR	Import	Export
RT Plan Label	(300A,0002)	LO	ID of imported Plan.	See ⁷ .
RT Plan Name	(300A,0003)	SH	Name of imported Plan.	See ⁷ .
RT Plan Description	(300A,0004)	ST		See ⁷ .
Instance Number	(0020,0013)	IS		
Operators' Name	(0008,1070)	PN	Creator of imported Plan, if no approval state is available.	
RT Plan Date	(300A,0006)	DA	Date of Imported Plan	
RT Plan Time	(300A,0007)	TM	Time of Imported Plan	
Plan Intent	(300A,000A)	CS		
RT Plan Geometry	(300A,000C)	CS	"PATIENT" only	"PATIENT" only
Referenced Structure Set Sequence	(300C,0060)	SQ		
>Referenced SOP Class UID	(0008,1150)	UI		
>Referenced SOP Instance UID	(0008,1155)	UI		
Referenced RT Plan Sequence	(300C,0002)	SQ		
>Referenced SOP Class UID	(0008,1150)	UI		
>Referenced SOP Instance UID	(0008,1155)	UI		
>RT Plan Relationship	(300A,0055)	CS	Not evaluated.	

Table 8-24: General RT Plan Module

⁷ It is possible to configure which string element will be assigned to which DICOM attribute for RT Plan Label (300A,0002), RT Plan Name (300A,0003) and RT Plan Description (300A,0004) in order to guarantee the correct assignment in different target systems.

8.1.2.3.10 RT Prescription Module

Attribute Name	Tag	VR	Import	Export
Dose Reference Sequence	(300A,0010)	SQ		See ⁸
>Dose Reference Number	(300A,0022)	IS		
>Dose Reference UID	(300A,0013)	UI		
>Dose Reference Structure Type	(300A,0014)	CS	"SITE" or "VOLUME"	"VOLUME", "COORDINATES" or "SITE"
>Dose Reference Description	(300A,0016)	ST		See ⁹ .
>Referenced ROI Number	(3006,0084)	IS		
>Dose Reference Point Coordinates	(300A,0018)	DS		
>Dose Reference Type	(300A,0020)	CS		"TARGET"
>Target Prescription Dose	(300A,0026)	DS	Target Dose in DoseReview	

Table 8-25: RT Prescription Module

8.1.2.3.11 RT Tolerance Tables Module

Attribute Name	Tag	VR	Import	Export
Tolerance Table Sequence	(300A,0040)	SQ	Not evaluated.	
>Tolerance Table Number	(300A,0042)	IS		
>Tolerance Table Label	(300A,0043)	SH		

Table 8-26: RT Tolerance Tables Module

⁸ The current version of the planning applications export multiple items within the Dose Reference Sequence, each representing a dose reference for a treated target, typically with the coordinate defined in the center of the target. An additional item is exported without a specific coordinate that is referred to as the "primary" Dose Reference. This is referenced from within the Fraction Group's Referenced Beam Sequence by using the Referenced Dose Reference UID. The Cumulative Dose Reference Coefficients to other non-primary Referenced Dose References are scaled accordingly with respect to the Beam Dose for the primary Dose Reference.

⁹ It is possible to configure the Dose Reference Description (300A,0016). The Description can either be the PTV Name, Isocenter Name and/or a Course ID.

8.1.2.3.12 RT Patient Setup Module

Attribute Name	Tag	VR	Import	Export
Patient Setup Sequence	(300A,0180)	SQ		
>Patient Setup Number	(300A,0182)	IS		
>Patient Setup Label	(300A,0183)	LO		
>Patient Position	(0018,5100)	CS	Only one orientation per RT Plan instance is supported.	"HFS"
>Setup Technique	(300A,01B0)	CS		"ISOCENTRIC"

Table 8-27: RT Patient Setup Module
8.1.2.3.13 RT Fraction Scheme Module

Attribute Name	Tag	VR	Import	Export
Fraction Group Sequence	(300A,0070)	SQ	See 10	
>Fraction Group Number	(300A,0071)	IS		
>Referenced Dose Reference Sequence	(300C,0050)	SQ		
>>Referenced Dose Reference Number	(300C,0051)	IS		
>Number of Fractions Planned	(300A,0078)	IS	Imported for Display.	
>Number of Beams	(300A,0080)	IS	Not evaluated.	
>Referenced Beam Sequence	(300C,0004)	SQ		
>>Beam Dose Specification Point	(300A,0082)	DS	Not evaluated.	Not created, can be activated. Only if RT Plan Geometry (300A,000C) is "PATIENT"
>Dose Reference UID	(300A,0013)	UI		References the "primary" Dose Reference item. Included for backward-compatibility.
>>Referenced Dose Reference UID	(300A,0083)	UI	Not evaluated	References the "primary" Dose Reference item.
>>Beam Dose	(300A,0084)	DS	May be evaluated for Target Dose in case Target Prescription Dose in Dose Reference Sequence is not available.	
>>Beam Dose Point Depth	(300A,0088)	DS	Not evaluated.	Only if RT Plan Geometry (300A,000C) is "PATIENT".
>>Beam Dose Equivalent Depth	(300A,0089)	DS	Not evaluated.	Only if RT Plan Geometry (300A,000C) is "PATIENT".
>>Beam Dose SSD	(300A,008A)	DS	Not evaluated.	Only if RT Plan Geometry (300A,000C) is "PATIENT". See ¹¹ .
>>Beam Meterset	(300A,0086)	DS	Not evaluated.	

¹⁰ Only one Number of Fractions Planned (300A,0078) is supported internally. In case there are more Items in the Fraction Group Sequence (300A,0070) it is evaluated whether all Number of Fractions Planned (300A,0078) have the same value, which is then imported. If these attributes differ in value, no number is imported.

¹¹ Within the Multiple Brain Mets SRS Application this value is defined as the distance from the source to the first point of the patient model along the line of the source to the Beam Dose Specification Point. This can either be the patient surface or the patient table, in case the beam starts below the patient support device.

>>Maximum Treatment Time	(3249,xx00)	DS	Not evaluated.	See 12.
>>Referenced Beam Number	(300C,0006)	IS		
>>Dose Reference UID	(300A,0013)	UI	Not evaluated.	Matches the "primary" Dose Reference Sequence (300A,0010) item.
>>Referenced Primary Dose Reference	(3249,xx10)	UI	Not evaluated.	Matches the "primary" Dose Reference Sequence (300A,0010) item.
>Number of Brachy Application Setups	(300A,00A0)	IS	Not evaluated.	Always "0"

Table 8-28: RT Fraction Scheme Module

8.1.2.3.14 RT Beams Module

Attribute Name	Tag	VR	Import	Export
Beam Sequence	(300A,00B0)	SQ	Only partially evaluated by RT Import Performer 1.0.	
>Beam Number	(300A,00C0)	IS	Imported for external references.	See ¹³ .
>Beam Name	(300A,00C2)	LO	Imported for external references.	See ¹³ .
>Beam Secondary Name	(3243,xx09)	SH	Not evaluated	See ¹⁴ .
>Beam Description	(300A,00C3)	LO	Not evaluated	See ¹³ .
>Beam Type	(300A,00C4)	CS	Not evaluated	"STATIC" or "DYNAMIC"
>Radiation Type	(300A,00C6)	CS	Not evaluated	"PHOTON"
>Primary Fluence Mode Sequence	(3002,0050)	SQ	Not evaluated	See ¹⁵ .
>>Fluence Mode	(3002,0051)	CS		
>>Fluence Mode ID	(3002,0052)	SH		"SRS" or "FFF"
>High Dose Technique Type	(300A,00C7)	CS	Not evaluated	if applicable "SRS"
>Treatment Machine Name	(300A,00B2)	SH		
>Manufacturer	(0008,0070)	LO		See ¹⁶ .
>Institution Name	(0008,0080)	LO	Not evaluated	
>Institutional Department Name	(0008,1040)	LO	Not evaluated	
>Manufacturer's Model Name	(0008,1090)	LO	Not evaluated	
>Primary Dosimeter Unit	(300A,00B3)	CS		"MU"
>Source-Axis Distance	(300A,00B4)	DS	Not evaluated	

¹² The presence of this attribute can be configured. It is calculated out of the Dose Rate Set (300A,0015) and the Beam Meterset (300A,0086). An additional factor can be applied to take any variances into account. A default factor of 1.3 is defined.

¹³ It is possible to configure which string element will be assigned to which DICOM attribute for Beam Number (300A,00C0), Beam Name (300A,00C2) and Beam Description (300A,00C3) in order to guarantee the correct assignment in different target systems.

¹⁴ The presence of this attribute can be configured. The content of its value is along the definition of ¹³.

¹⁵ As a default the Primary Fluence Mode Sequence (3002,0050) is written with the Primary Fluence Mode (3002,0051) set to "STANDARD". For cases where this causes an issue, this behavior can be changed in the application settings. For a Primary Fluence Mode "NON_STANDARD" this sequence will always be written.

¹⁶ Some target systems do not interpret this value as the manufacturer of the treatment delivery device, but as the manufacturer of the beam-limiting device. Therefore, the value of this attribute can be configured accordingly.

>Beam Limiting Device Sequence	(300A,00B6)	SQ	Not evaluated	
>>RT Beam Limiting Device Type	(300A,00B8)	CS		
>>Number of Leaf/Jaw Pairs	(300A,00BC)	IS		
>>Leaf Position Boundaries	(300A,00BE)	DS		
>Referenced Patient Setup Number	(300C,006A)	IS	Not evaluated	
>Treatment Delivery Type	(300A,00CE)	CS		"TREATMENT"
>Number of Wedges	(300A,00D0)	IS	Not evaluated	"0"
>Number of Blocks	(300A,00F0)	IS	Not evaluated	"0"
>Number of Compensators	(300A,00E0)	IS	Not evaluated	"0"
>Number of Boli	(300A,00ED)	IS	Not evaluated	"0"
>Final Cumulative Meterset Weight	(300A,010E)	DS	Not evaluated	"1.0"
>Number of Control Points	(300A,0110)	IS	Not evaluated	
>Control Point Sequence	(300A,0111)	SQ		
>>Control Point Index	(300A,0112)	IS		
>>Cumulative Meterset Weight	(300A,0134)	DS	Not evaluated	
>>Referenced Dose Reference Sequence	(300C,0050)	SQ	Not evaluated	
>>>Referenced Dose Reference Number	(300C,0051)	IS		
>>>Cumulative Dose Reference Coefficient	(300A,010C)	DS		
>>>Beam Dose Point Depth	(300A,0088)	DS		Only if RT Plan Geometry (300A,000C) is "PATIENT".
>>>Beam Dose Equivalent Depth	(300A,0089)	DS		Only if RT Plan Geometry (300A,000C) is "PATIENT".
>>>Beam Dose SSD	(300A,008A)	DS		Only if RT Plan Geometry (300A,000C) is "PATIENT". See ¹⁷ .
>>Nominal Beam Energy	(300A,0114)	DS	Not evaluated	
>>Dose Rate Set	(300A,0115)	DS		See ¹⁸ .
>>Beam Limiting Device Position Sequence	(300A,011A)	SQ	Not evaluated	
>>>RT Beam Limiting Device Type	(300A,00B8)	CS		
>>>Leaf/Jaw Positions	(300A,011C)	DS		
>>Gantry Angle	(300A,011E)	DS		
>>Gantry Rotation Direction	(300A,011F)	CS	See ¹⁹	
>>Beam Limiting Device Angle	(300A,0120)	DS		

¹⁷ This value is defined as the distance from the source to the first point of the patient model along the line of the source to the Beam Dose Specification Point. This can either be the patient surface or the patient table, in case the beam starts below the patient support device.

¹⁸ It is possible to configure how the Dose Rate Set (300A,0115) is written.

¹⁹ The Gantry Rotation Direction (300A,011F) shall be consistent within a single beam, i.e. either CW or CC, but intermittent Control Points with a Gantry Rotation Direction NONE are tolerated.

>>Beam Limiting Device Rotation Direction	(300A,0121)	CS		
>>Patient Support Angle	(300A,0122)	DS		
>>Patient Support Rotation Direction	(300A,0123)	CS		
>>Table Top Eccentric Angle	(300A,0125)	DS	Not evaluated	
>>Table Top Eccentric Rotation Direction	(300A,0126)	CS	Not evaluated	
>>Table Top Pitch Angle	(300A,0140)	DS	Not evaluated	
>>Table Top Pitch Rotation Direction	(300A,0142)	CS	Not evaluated	
>>Table Top Roll Angle	(300A,0144)	DS	Not evaluated	
>>Table Top Roll Rotation Direction	(300A,0146)	CS	Not evaluated	
>>Table Top Vertical Position	(300A,0128)	DS	Not evaluated	
>>Table Top Longitudinal Position	(300A,0129)	DS	Not evaluated	
>>Table Top Lateral Position	(300A,012A)	DS	Not evaluated	
>>Isocenter Position	(300A,012C)	DS		Only if RT Plan Geometry (300A,000C) is "PATIENT"
>>Source to Surface Distance	(300A,0130)	DS	Not evaluated	Only if RT Plan Geometry (300A,000C) is "PATIENT". See ²⁰
>>Source to External Contour Distance	(300A,0132)	FL	Not evaluated	See ²¹

Table 8-29: RT Beams Module

8.1.2.3.15 Extended Interface Module

Attribute Name	Tag	VR	Import	Export
Extended Interface Data	(3253,xx00)	OB	Not evaluated	
Extended Interface Length	(3253,xx01)	IS	Not evaluated	
Extended Interface Format	(3253,xx02)	LO	Not evaluated	

Table 8-30: Varian Extended Interface Module

8.1.2.3.16 RT Dose Module

Attribute Name	Tag	VR	Import	Export
Samples per Pixel	(0028,0002)	US		
Photometric Interpretation	(0028,0004)	CS		
Bits Allocated	(0028,0100)	US	16 or 32	16 or 32
Bits Stored	(0028,0101)	US	16 or 32	16 or 32

²⁰ This value is defined as the distance from the source to the first point of the patient model along the line of the source to the Isocenter Position (300A,012C). This can either be the patient surface or the patient table, in case the beam starts below the patient support device.

²¹ The 2015a revision of the DICOM Standard clarified the proper semantics for the Source to Surface Distance (300A,0130) as it was not clear what the "surface" referred to. For backward-compatibility the value calculated by the Brainlab treatment planning applications is still available through the Source to Surface Distance (300A,0130) attribute, but it is possible to configure this value to be present in Source to External Contour Distance (300A,0132).

High Bit	(0028,0102)	US	15 or 31	15 or 31
Pixel Representation	(0028,0103)	US		
Dose Units	(3004,0002)	CS	GY	"GY"
Dose Type	(3004,0004)	CS	"PHYSICAL"	"PHYSICAL"
Dose Comment	(3004,0006)	LO		
Dose Summation Type	(3004,000A)	CS	"PLAN"	"PLAN", "FRACTION" or "BEAM"
Referenced RT Plan Sequence	(300C,0002)	SQ		
>Referenced SOP Class UID	(0008,1150)	UI	²²	
>Referenced SOP Instance UID	(0008,1155)	UI		
>Referenced Fraction Group Sequence	(300C,0020)	SQ	Not evaluated.	
>>Referenced Fraction Group Number	(300C,0022)	IS		
>>Referenced Beam Sequence	(300C,0004)	SQ		See ²³ .
>>>Referenced Beam Number	(300C,0006)	IS		
Grid Frame Offset Vector	(3004,000C)	DS		
Dose Grid Scaling	(3004,000E)	DS		

Table 8-31: RT Dose Module

8.1.2.3.17 RT DVH Module

Attribute Name	Tag	VR	Import	Export
Referenced Structure Set Sequence	(300C,0060)	SQ	Not evaluated.	
>Referenced SOP Class UID	(0008,1150)	UI		
>Referenced SOP Instance UID	(0008,1155)	UI		
DVH Sequence	(3004,0050)	SQ	Not evaluated.	See ²⁴
>DVH Referenced ROI Sequence	(3004,0060)	SQ		
>>Referenced ROI Number	(3006,0084)	IS		
>>DVH ROI Contribution Type	(3004,0062)	CS		"INCLUDED"
>DVH Type	(3004,0001)	CS		"DIFFERENTIAL"
>Dose Units	(3004,0002)	CS		"GY"
>Dose Type	(3004,0004)	CS		"PHYSICAL"
>DVH Dose Scaling	(3004,0052)	DS		
>DVH Volume Units	(3004,0054)	CS		"CM3"
>DVH Number of Bins	(3004,0056)	IS		
>DVH Data	(3004,0058)	DS		
>DVH Minimum Dose	(3004,0070)	DS		
>DVH Maximum Dose	(3004,0072)	DS		
>DVH Mean Dose	(3004,0074)	DS		

²² If several RT Dose instances reference the same DICOM RT Plan instance, they will all be added to the same internal plan as long as they refer to the same Frame of Reference as the DICOM RT Plan.

²³ If a beam is split during export due to field size or beam meterset and Dose Summation Type is set to "BEAM" then the Referenced Beam Sequence will contain more than one item in order to represent the dose volume of one conceptual treatment beam.

²⁴ In case a DVH exported, this is always present in a separate RT Dose instance, where no volumetric dose information is present. Therefore, no pixel-related modules will be present either.

Table 8-32: RT DVH Module

8.1.3 Usage of Attributes from Received IODs

8.1.3.1 Image IODs

8.1.3.1.1 General

In general the applications and performers support any kind of DICOM image, but there are some restrictions:

- Grayscale with 1 samples per pixel and 8 or 16 bits allocated
- Color with 3 samples per pixel, "RGB", "YBR_FULL" or "YBR_FULL_422", 8 bits allocated and unsigned pixel representation
- Palette color with 1 sample per pixel and 8 or 16 bits allocated

All other image formats are not supported and therefore will not be displayed.

8.1.3.1.2 CT Image Storage / Enhanced CT Image Storage

If one of the following criteria is fulfilled the dataset is not processed as CT but as 3D X-Ray:

- (0008,0060) Modality is "XA" and (0008,1090) Manufacturers Model Name is "XtraVision" and (0008,0008) Image Type contains either "3DRA_PROP", "3DRA_ROLL", "3DRX_PROP" or "3DRX_ROLL"
- (0029,xx04) Private Creator with value "Navigation" exists
- (0008,0008) Image Type contains "BrainlabVario3DNavigation"
- (0008,0008) Image Type contains "Vario3D"
- (0029,xx04) Private Creator with value "ISOC 3D NAVIGATIONMATRIX.R. 1.0" exists
- (0008,0008) Image Type contains "ISOC_3D"
- (0008,1090) Manufacturers Model Name is "AXIOM-Artis" and (0018,1210) Convolution Kernel is "EE"
- (0008,0016) SOP Class UID contains "1.3.46.670589.2.4.1.1"
- The histogram area of the pixel data transformed by the Modality LUT significantly exceeds the Hounsfield range from -1024 to 3072 by more than 20%.

8.1.3.1.3 Positron Emission Tomography Image Storage

If one of the following criteria is supported the PET Image is accepted:

- (0054,1000) Series Type Value 1 is STATIC or WHOLE BODY
- (0054,1000) Series Type Value 1 is DYNAMIC and (0054,0101) Number of Time Slices is 1

8.1.3.2 Segmentation IODs

The applications do not support Segmentation instances with a Segmentation Type (0062,0001) of "BINARY" and Columns (0028,0011) with a value which is not a multiple of 8.

8.1.3.3 Patient Identification

In all applications and performers a patient is considered as the same patient if (0010,0010) Patient's Name, (0010,0020) Patient ID and (0010,0030) Patient's Birth Date are the same. The

name and id comparison is case insensitive. Which name components to compare is configurable, by default the full name with all components will be used.

If an application or performer isn't able to identify correctly the patient the according data set won't be loaded and this error is either stated in a dialog or a log file.

8.1.3.4 Frame of Reference and Image References

The usage of the Frame of Reference in the DICOM standard assumes that it is always accurate and well-defined. In fact, this is correct for e.g. spatial positions of DICOM objects, such as image positions.

However, since the content of e.g. images is the relevant information, it may happen that although the spatial / temporal relation is correctly defined, the spatial or temporal content is not well defined and therefore not correctly related.

As a consequence, Brainlab applications and performers will only use a Frame of Reference in non-image SOP classes if the corresponding Image SOP instances are referenced in addition to the Frame of Reference.

8.1.4 Attribute Mapping

No attribute mapping is performed.

8.1.5 Coerced/Modified fields

No coercion is performed.

8.2 Data Dictionary of Private Attributes

The Private Attributes added to SOP Instances are listed in the table below. Further details on usage of these private attributes are contained in Section 8.1.

8.2.1 Group 0009

Tag	Attribute Name	VR	VM
(0009,00xx)	Private Creator Code 'BrainLAB_Conversion'	LO	1
(0009,xx01)	Export Platform Name	LO	1
(0009,xx51)	Export Platform Checksum	OB	1

Table 8-33: Export Platform Parameter

8.2.2 Group 3243

Tag	Attribute Name	VR	VM
(3243,00xx)	Private Creator Code 'Varian Medical Systems VISION 3243'	LO	1
(3243,xx09)	Beam Secondary Name	SH	1

Table 8-34: Varian Group 3243 [5]

8.2.3 Group 3249

Tag	Attribute Name	VR	VM
(3249,00xx)	Private Creator Code 'Varian Medical Systems VISION 3249'	LO	1
(3249,xx00)	Maximum Treatment Time	DS	1
(3249,xx10)	Referenced Primary Reference UID	UI	1

Table 8-35: Varian Group 3249 [5]

8.2.4 Group 3253

Tag	Attribute Name	VR	VM
(3253,00xx)	Private Creator Code 'Varian Medical Systems VISION 3253'	LO	1
(3253,xx00)	Extended Interface Data	OB	1
(3253,xx01)	Extended Interface Length	IS	1
(3253,xx02)	Extended Interface Format	LO	1

Table 8-36: Varian Group 3253 [5]

8.3 Coded Terminology and Templates

See [1].

8.4 Grayscale Image Consistency

Not supported.

8.5 Standard Extended/Specialized/Private SOP Classes

None

8.6 Private Transfer Syntaxes

None.

9 Indexes

9.1 Index of Tables

Table 1-1: Common Management Applications	3
Table 1-2: Applications.....	4
Table 1-3: Performers	4
Table 1-4: Supported network services	7
Table 1-5: Supported media profiles	8
Table 4-1: Commonly supported Transfer Syntaxes (for association negotiation)	20
Table 4-2: Superset of supported Storage SOP Classes with Transfer Syntax mapping	22
Table 4-3: Superset of supported Query/Retrieve SOP Classes with Transfer Syntax mapping	23
Table 4-4: Commonly proposed Application Context Name	23
Table 4-5: Commonly supported number of associations	23
Table 4-6: Commonly proposed Presentation Contexts - Find Studies, Series and Instances... ..	24
Table 4-7: Patient Root and Study Root Request Identifier for FIND-SCU	25
Table 4-8: Patient Selection proposed Presentation Contexts – Find Patient	25
Table 4-9: RT Preparation Application supported SOP Classes	27
Table 4-10: RT Preparation Application proposed Presentation Contexts – Save Instances	28
Table 4-11: Multiple Brain Mets SRS Application supported SOP Classes.....	29
Table 4-12: Multiple Brain Mets SRS Application proposed Presentation Contexts – Save Instances.....	30
Table 4-13: Cranial SRS Application supported SOP Classes	31
Table 4-14: Cranial SRS Application proposed Presentation Contexts – Save Instances.....	32
Table 4-15: Cranial SRS w/ Cones Application supported SOP Classes.....	33
Table 4-16: Cranial SRS w/ Cones Application proposed Presentation Contexts – Save Instances.....	34
Table 4-17: Spine SRS Application supported SOP Classes.....	35
Table 4-18: Spine SRS Application proposed Presentation Contexts – Save Instances.....	36
Table 4-19: Dose Review Application supported SOP Classes	37
Table 4-20: RT QA Application supported SOP Classes	39
Table 4-21: RT QA Application proposed Presentation Contexts – Save Instances	40
Table 4-22: DICOM RT Export Performer supported SOP Classes.....	41
Table 4-23: DICOM RT Export Performer proposed Presentation Contexts – Save Instances ..	42
Table 4-24: DICOM RT Import Performer supported SOP Classes	43
Table 4-25: DICOM RT Import Performer proposed Presentation Contexts – Save Instances ..	44
Table 5-1: Multiple Brain Mets SRS supported Media Interchange Profiles.....	48
Table 5-2: Patient Selection supported SOP Classes and Transfer Syntaxes	48
Table 5-3: Brainlab BL-EXPORT Profiles.	49
Table 5-4: BL-RT-EXPORT SOP Classes and Transfer Syntaxes.	50
Table 6-1: Application and performer specific supported character sets.....	51
Table 8-1: RT Structure Set Storage IOD	55
Table 8-2: RT Plan Storage IOD	56
Table 8-3: RT Dose Storage IOD	56
Table 8-4: Patient Module	57
Table 8-5: General Study Module.....	57
Table 8-6: Patient Study Module	58
Table 8-7: General Series Module.....	58
Table 8-8: Frame of Reference Module.....	58

Table 8-9: (Enhanced) General Equipment Module.....	58
Table 8-10: General Image Module.....	59
Table 8-11: Image Pixel Module.....	59
Table 8-12: Image Plane Module.....	59
Table 8-13: Multi-frame Module.....	59
Table 8-14: SOP Common Module.....	60
Table 8-15: Common Instance Reference Module.....	60
Table 8-16: RT Series Module.....	60
Table 8-17: General Image Module (RT Dose).....	60
Table 8-18: General Image Module.....	61
Table 8-19: Image Pixel Module (RT Dose).....	61
Table 8-20: Structure Set Module.....	62
Table 8-21: ROI Contour Module.....	63
Table 8-22: RT ROI Observations Module.....	63
Table 8-23: Approval Module.....	63
Table 8-24: General RT Plan Module.....	64
Table 8-25: RT Prescription Module.....	65
Table 8-26: RT Tolerance Tables Module.....	65
Table 8-27: RT Patient Setup Module.....	66
Table 8-28: RT Fraction Scheme Module.....	67
Table 8-29: RT Beams Module.....	69
Table 8-30: Varian Extended Interface Module.....	69
Table 8-31: RT Dose Module.....	70
Table 8-32: RT DVH Module.....	71
Table 8-33: Export Platform Parameter.....	73
Table 8-34: Varian Group 3243 [5].....	73
Table 8-35: Varian Group 3249 [5].....	73
Table 8-36: Varian Group 3253 [5].....	73

9.2 Index of Figures

Figure 1-1: Overview of a Brainlab system running applications and performers.....	3
Figure 4-1: Patient Selection Application Data Flow Diagram.....	15
Figure 4-2: General Application Data Flow Diagram.....	15
Figure 4-3: General Performer Data Flow Diagram.....	16
Figure 4-4: Simplified sequencing of the standard interactive use case.....	18
Figure 4-5: Simplified sequencing of Performer activities.....	19
Figure 5-1: The Patient Selection Data Flow Diagram.....	47