

Technical Publication

DICOM Conformance Statement
Digital Lightbox 1.5

Document Revision 2

April 30, 2009

2009 © Copyright BrainLAB AG



1 Conformance Statement Overview

This is a conformance statement for the BrainLAB software Digital Lightbox. One main purpose of this software is to import and visualize DICOM data.

The DICOM import part of the application is

- Browse and display of DICOM files (e.g. removable media)
- Query remote DICOM archives
- Retrieve DICOM data from archives
- Receive DICOM data from other DICOM nodes (e.g. archives or workstations) via the network

The application does not store, export or archive any DICOM data.

SOP Classes	User Of Service (SCU)	Provider Of Service (SCP)
Transfer		
Computed Radiography Image Storage	No	Yes
CT Image Storage	No	Yes
MR Image Storage	No	Yes
US Image Storage	No	Yes
US Multiframe Image Storage	No	Yes
Secondary Capture (SC) Image Storage	No	Yes
Multi-frame Grayscale Byte Secondary Capture Image Storage	No	Yes
Multi-frame Grayscale Word Secondary Capture Image Storage	No	Yes
Multi-frame True Color Secondary Capture Image Storage	No	Yes
Standalone PET Curve Storage	No	Yes
X-Ray Angiographic Image Storage	No	Yes
X-Ray Radiofluoroscopic (RF) Image Storage	No	Yes
Nuclear Medicine Image Storage	No	Yes
Raw Data Storage	No	Yes
Positron Emission Tomography Image Storage	No	Yes
Query/Retrieve		
Patient Root Query/Retrieve Information Model - FIND	Yes	No
Patient Root Query/Retrieve Information Model - MOVE	Yes	No
Study Root Query/Retrieve Information Model - FIND	Yes	No
Study Root Query/Retrieve Information Model - MOVE	Yes	No
Patient/Study Only Query/Retrieve Information Model - FIND	Yes	No
Patient/Study Only Query/Retrieve Information Model – MOVE	Yes	No

Table 1-1: Network services supported by Digital Lightbox

Media Storage Application Profile	Write Files (FSC or FSU)	Read Files (FSR)
Compact Disc – Recordable		
General Purpose CD–R	No	Yes

Table 1-2: Media Services supported by Digital Lightbox

2 Table Of Contents

1	Conformance Statement Overview	3
2	Table Of Contents	5
3	Introduction	7
3.1	Revision History	7
3.2	Audience	7
3.3	Remarks	7
3.4	Abbreviations	8
3.5	References	8
4	Networking	9
4.1	Implementation Model	9
4.1.1	Application Data Flow Diagram	10
4.1.2	Functional Definition of Application Entity (AE)	11
4.1.3	Sequencing Of Real World Activities	12
4.2	Application Entity Specifications	12
4.2.1	Digital Lightbox Specification	12
4.2.1.1	SOP Classes and Transfer Syntaxes	12
4.2.1.2	Association Policies	14
4.2.1.2.1	General	14
4.2.1.2.2	Number of Associations	14
4.2.1.2.3	Asynchronous Nature	14
4.2.1.2.4	Implementation Identifying Information	14
4.2.1.3	Association Initiation Policy	14
4.2.1.3.1	Activity – Find	14
4.2.1.3.2	Activity – Retrieve	15
4.2.1.4	Association Acceptance Policy	16
4.2.1.4.1	Activity – Retrieve	16
4.2.1.4.2	Activity – Receive	16
4.3	Network Interfaces	17
4.3.1	Physical Network Interface	17
4.3.2	Additional Protocols	17
4.4	Configuration	17
4.4.1	AE Title / Presentation Address Mapping	17
4.4.1.1	Local AE Titles	17
4.4.1.2	Remote AE Title/Presentation Address Mapping	18
4.4.2	Parameters	18
5	Media Interchange	19
5.1	Implementation Model	19
5.1.1	Application Data Flow Diagram	19
5.1.2	Functional Definition of Application Entity (AE)	19
5.1.3	Sequencing Of Real World Activities	19
5.1.4	File Meta Implementation Identifying Information	19
5.2	Application Entity Specifications	20
5.2.1	Media Interchange Profile	20
5.3	Augmented And Private Application Profiles	20
5.4	Media Configuration	20

6	Support Of Extended Character Sets	21
7	Security Profiles	22
8	Annexes	23
8.1	IOD Contents	23
8.1.1	Usage Of Attributes From Received IODs	23
8.1.1.1	Images	23
8.2	Data Dictionary Of Private Attributes	24
8.3	Coded Terminology And Templates	24
8.4	Grayscale Image Consistency	24
8.5	Standard Extended/Specialized/Private Sop Classes	24
8.6	Private Transfer Syntaxes	24
9	Indexes	25
9.1	Index Of Tables	25
9.2	Index Of Figures	25

3 Introduction

3.1 Revision History

Document Version	Date of Issue	Author	Description
1	June 3, 2008	HAO	Initial release for Digital Lightbox 1.0
2	April 30, 2009	HAO	Updated Digital Lightbox version to 1.5

3.2 Audience

This document is intended for hospital staff, health system integrators, software designers or implementers. It is assumed that the reader has a working understanding of DICOM.

3.3 Remarks

DICOM, by itself, does not guarantee interoperability. However, the Conformance Statement facilitates a first-level validation for interoperability between different applications supporting the same DICOM functionality. The Conformance Statement should be read and understood in conjunction with the DICOM Standard [1]. However, by itself it is not guaranteed to ensure the desired interoperability and a successful interconnectivity.

The user should be aware of the following important issues:

- The comparison of different conformance statements is the first step towards assessing interconnectivity between BrainLAB and non–BrainLAB equipment.
- This Conformance Statement is not intended to replace validation with other DICOM equipment to ensure proper exchange of information intended. An acceptance protocol is available to validate the desired level of connectivity.
- The DICOM standard will evolve to meet the users' future requirements. BrainLAB reserves the right to make changes to its products or to discontinue its delivery.

3.4 Abbreviations

There are a variety of terms and abbreviations used in the document that are defined in the DICOM Standard. Abbreviations and terms are as follows:

AE	DICOM Application Entity
AET	Application Entity Title
CD	Compact Disk
CD-R	Compact Disk Recordable
DVD	Digital Versatile Disc
FSC	File-Set Creator
FSU	File-Set Updater
FSR	File-Set Reader
HD	Hard Disk
IOD	(DICOM) Information Object Definition
ISO	International Standard Organization
MOD	Magneto Optical Disk
PDU	DICOM Protocol Data Unit
Q/R	Query and Retrieve
SCU	DICOM Service Class User (DICOM client)
SCP	DICOM Service Class Provider (DICOM server)
SOP	DICOM Service-Object Pair

3.5 References

- [1] Digital Imaging and Communications in Medicine (DICOM) 3.0, NEMA PS 3.1-3.18 – 2006
- [2] DICOM Conformance Statement Converting DICOM Service 1.0, BrainLAB, April 19, 2005

4 Networking

4.1 Implementation Model

The BrainLAB Digital Lightbox application is an implementation of:

- A Query/Retrieve SCU to query DICOM archives and to initiate a move request for the queried archive.
- A Media File Set Reader to load DICOM data from a file system.
- A Storage SCP that receives DICOM data from other DICOM archives or workstations.
- A visualization of imported DICOM data

4.1.1 Application Data Flow Diagram

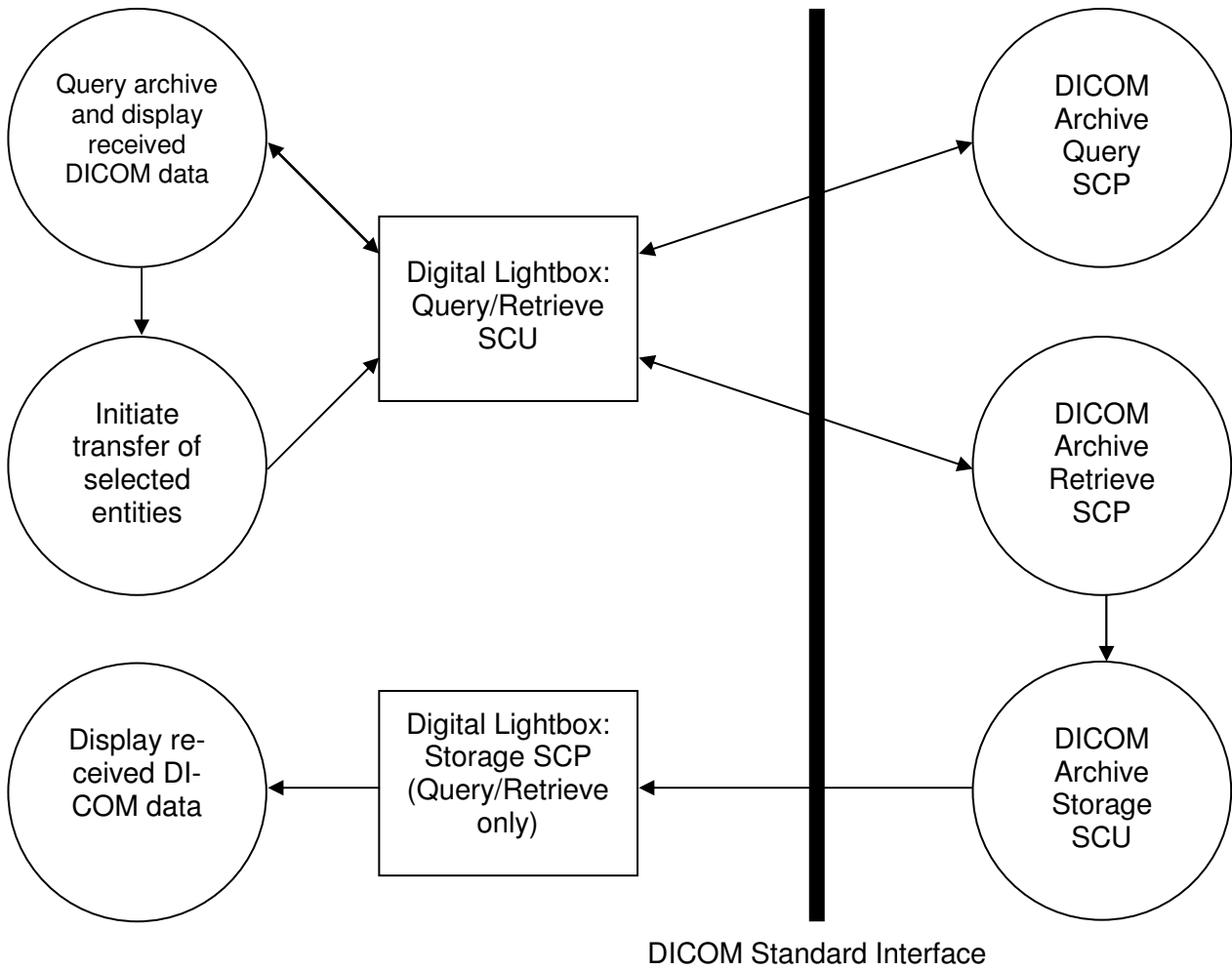

Figure 4-1: The Query/Retrieve SCU application flow diagram

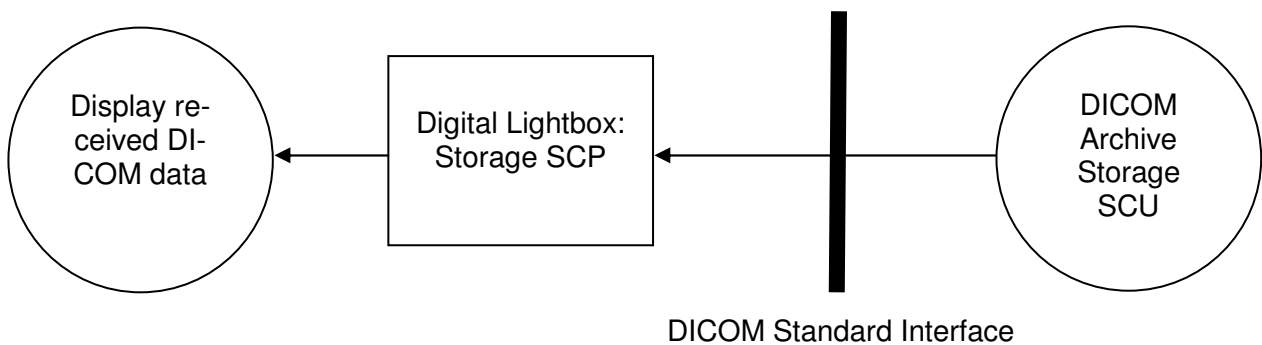

Figure 4-2: The Storage SCP application flow diagram

4.1.2 Functional Definition of Application Entity (AE)

Some communications and data transfer with remote AEs are accomplished utilizing the DICOM protocol over a network using the TCP/IP protocol stack.

- **Query and Retrieve:**
The user wants to find a certain dataset in a DICOM archive. Digital Lightbox initiates an association as a Q/R SCU negotiating all models. The find request can be performed (depending on the negotiated models) on all DICOM levels (patient, study, series or instance). For a selected DICOM entity (patient, study, series or instance) a move request can be performed. The application supplies all unique keys for the requested level. The move response, indicating the storage-progress, is graphically evaluated.
- **Storage SCP:**
With the start of the Digital Lightbox a DICOM Storage SCP is invoked. It accepts any association with a Storage SCU negotiating any of the SOP Classes listed in Table 4-3. The Storage SCP only accepts one association at a time.

Further, during a move operation a DICOM Storage SCP is invoked. Digital Lightbox accepts an association with a Storage SCU negotiating any of the SOP Classes listed in Table 4-3.

4.1.3 Sequencing Of Real World Activities

Digital Lightbox Query/Retrieve SCU performs a sequencing of real world activities as follows:

1. Query Archive and display received DICOM data:
 - a. Send DICOM Query/Retrieve C-FIND request.
 - b. Receive DICOM Query/Retrieve C-FIND responses.
2. User selects data to retrieve.
3. Initiate transfer of selected entities:
 - a. Start the DICOM Storage SCP
 - b. Send a DICOM Query/Retrieve C-MOVE request
 - c. Receive DICOM C-STORE requests with the requested SOP instances.
 - d. Receive DICOM Query/Retrieve C-MOVE responses
 - e. Stop the DICOM Storage SCP

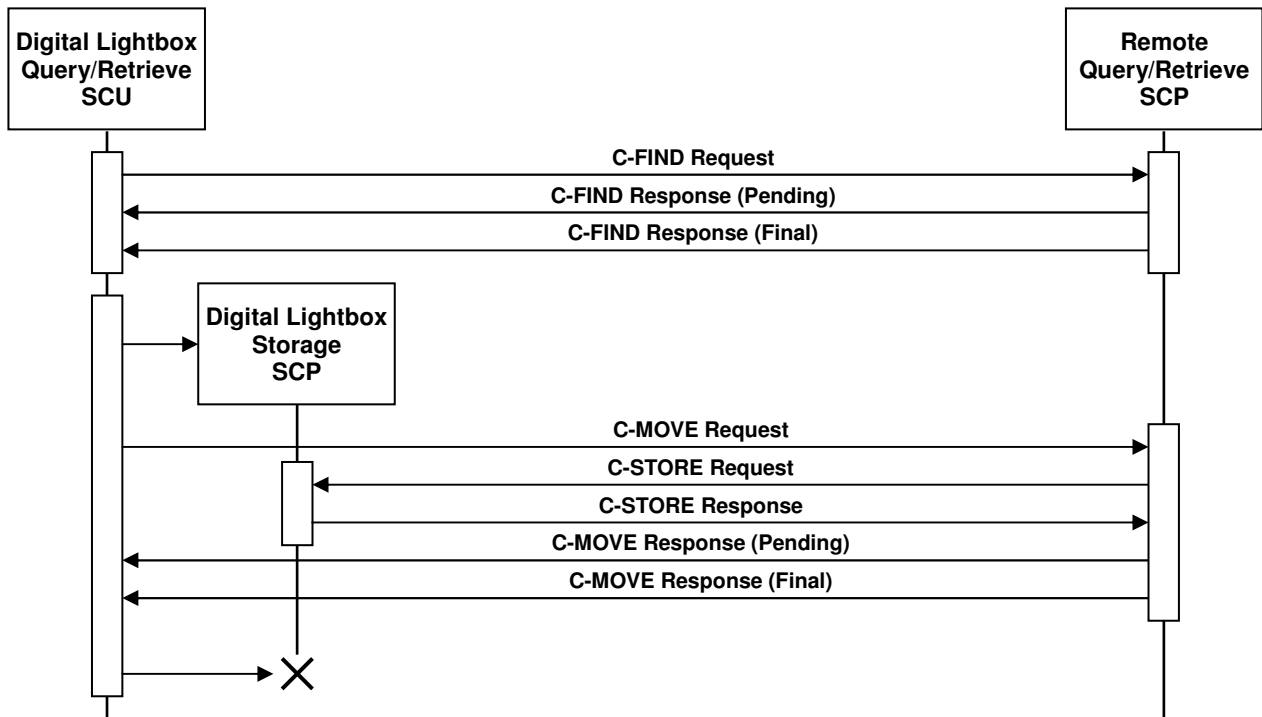

Figure 4-3: Sequencing of Query/Retrieve SCU and Storage SCP

4.2 Application Entity Specifications

4.2.1 Digital Lightbox Specification

4.2.1.1 SOP Classes and Transfer Syntaxes

Digital Lightbox sends or receives a C-ECHO request in order to test the connection to a remote AE. It provides standard conformance to the following DICOM V3.0 SOP Classes:

SOP Class Name	SOP Class UID	SCU	SCP
Verification SOP Class	1.2.840.10008.1.1	Yes	Yes

Table 4-1: Supported Verification SOP Classes

Digital Lightbox is able to query a remote archive. It provides Standard Conformance to the following DICOM V3.0 SOP Classes:

SOP Class Name	SOP Class UID	SCU	SCP
Patient Root Query/Retrieve Information Model - FIND	1.2.840.10008.5.1.4.1.2.1.1	Yes	No
Patient Root Query/Retrieve Information Model - MOVE	1.2.840.10008.5.1.4.1.2.1.2	Yes	No
Study Root Query/Retrieve Information Model - FIND	1.2.840.10008.5.1.4.1.2.2.1	Yes	No
Study Root Query/Retrieve Information Model - MOVE	1.2.840.10008.5.1.4.1.2.2.2	Yes	No
Patient/Study Only Query/Retrieve Information Model - FIND	1.2.840.10008.5.1.4.1.2.3.1	Yes	No
Patient/Study Only Query/Retrieve Information Model - MOVE	1.2.840.10008.5.1.4.1.2.3.2	Yes	No

Table 4-2: Supported Query/Retrieve SOP Classes

Digital Lightbox imports DICOM image data. It provides Standard Conformance to the following DICOM V3.0 SOP Classes:

SOP Class Name	SOP Class UID	SCU	SCP
CR Image Storage	1.2.840.10008.5.1.4.1.1.1	No	Yes
CT Image Storage	1.2.840.10008.5.1.4.1.1.2	No	Yes
MR Image Storage	1.2.840.10008.5.1.4.1.1.4	No	Yes
US Image Storage	1.2.840.10008.5.1.4.1.1.6.1	No	Yes
US Multiframe Image Storage	1.2.840.10008.5.1.4.1.1.3.1	No	Yes
Secondary Capture (SC) Image Storage	1.2.840.10008.5.1.4.1.1.7	No	Yes
Multi-frame Grayscale Byte 2ndary Capture Image Storage	1.2.840.10008.5.1.4.1.1.7.2	No	Yes
Multi-frame Grayscale Word 2ndary Capture Image Storage	1.2.840.10008.5.1.4.1.1.7.3	No	Yes
Multi-frame True Color 2ndary Capture Image Storage	1.2.840.10008.5.1.4.1.1.7.4	No	Yes
X-Ray Angiographic Image Storage	1.2.840.10008.5.1.4.1.1.12.1	No	Yes
X-Ray Radiofluoroscopic (RF) Image Storage	1.2.840.10008.5.1.4.1.1.12.2	No	Yes
Nuclear Medicine Image Storage	1.2.840.10008.5.1.4.1.1.20	No	Yes
Raw Data Storage	1.2.840.10008.5.1.4.1.1.66	No	Yes
Positron Emission Tomography Image Storage	1.2.840.10008.5.1.4.1.1.128	No	Yes

Table 4-3: Supported Storage SOP Classes

Digital Lightbox supports the following transfer syntaxes. In an association negotiation the syntaxes are proposed in the order of appearance in the list.

Transfer Syntax Name	Transfer Syntax UID	SCU	SCP
DICOM Implicit VR Little Endian	1.2.840.10008.1.2	Yes	Yes
DICOM Explicit VR Little Endian	1.2.840.10008.1.2.1	Yes	Yes

DICOM Explicit VR Big Endian	1.2.840.10008.1.2.2	Yes	Yes
JPEG Lossless, Non-Hierarchical, First-Order Prediction (Process 14)	1.2.840.10008.1.2.4.70	No	Yes

Table 4-4: Supported Transfer Syntaxes

4.2.1.2 Association Policies

4.2.1.2.1 General

The DICOM standard application context name for DICOM 3.0 is always proposed:

Application Context Name	1.2.840.10008.3.1.1.1
--------------------------	-----------------------

4.2.1.2.2 Number of Associations

For both association initiation and acceptance:

Maximum number of simultaneous Associations	1
---	---

4.2.1.2.3 Asynchronous Nature

The Digital Lightbox does not support asynchronous communication (multiple outstanding transactions over a single association).

Maximum number of outstanding asynchronous transactions	1
---	---

4.2.1.2.4 Implementation Identifying Information

The implementation information for this Application Entity is:

Implementation Class UID	1.2.276.0.20.1.1.12.1.0.0
Implementation Version Name	DIGITALLIGHTBOX1

4.2.1.3 Association Initiation Policy

Digital Lightbox initiates an association in these cases:

1. Find: The user tries to find a specific entity in a remote DICOM archive.
2. Retrieve: The user wants to retrieve a specific entity from the remote DICOM archive.

4.2.1.3.1 Activity – Find

4.2.1.3.1.1 Description and Sequencing of Activities

A DICOM Query/Retrieve C-FIND request is performed when the user queries the remote DICOM archive for patients, studies, series or instances.

4.2.1.3.1.2 Proposed Presentation Contexts

Presentation Context Table			
Abstract Syntax	Transfer Syntax	Role	Ext. Neg.
All SCU SOP Classes listed in Table 4-1 and all FIND SCU SOP Classes as listed in Table 4-2	All SCU Transfer Syntaxes as listed in Table 4-4	SCU	None
		SCU	None
		SCU	None

Table 4-5: Proposed Presentation Contexts for Activity Find.

4.2.1.3.1.3 SOP Specific Conformance

Digital Lightbox provides standard conformance to the DICOM Verification Service Class and to the DICOM Query/Retrieve FIND SOP Classes. No extended negotiation is implemented.

For the patient-root and patient/study only model, the user may restrict the patient query by the following attributes:

Attribute Name	Tag
Patient's Name	(0010,0010)
Patient ID	(0010,0020)

For the study-root model, the user may restrict the patient/study query by the following attributes:

Description	Tag
Patient's Name	(0010,0010)
Patient ID	(0010,0020)
Study Date	(0008,0020)
Accession Number	(0008,0050)

4.2.1.3.2 Activity – Retrieve

4.2.1.3.2.1 Description and Sequencing of Activities

On user selection of a specific DICOM study or series (depends on the available SOP Class for Query/Retrieve), a move request is performed. The storage target for receiving the DICOM data (the AET with which the move-request is equipped) is the Digital Lightbox application itself.

The Move operation only can be invoked after a Find operation. See chapter 4.1.3 for a detailed sequencing diagram.

4.2.1.3.2.2 Proposed Presentation Contexts

Presentation Context Table			
Abstract Syntax	Transfer Syntax	Role	Ext. Neg.
All SCU SOP Classes listed in Table 4-1 and all SCU MOVE SOP Classes as listed in Table 4-2	All SCU Transfer Syntaxes as listed in Table 4-4	SCU	None
		SCU	None
		SCU	None

Table 4-6: Proposed Presentation Contexts for Activity Move.

4.2.1.3.2.3 SOP Specific Conformance

Digital Lightbox provides standard conformance to the DICOM Verification Service Class and to the DICOM Query/Retrieve MOVE SOP Classes. No extended negotiation is implemented.

4.2.1.4 Association Acceptance Policy

Digital Lightbox accepts an association in this case:

1. Retrieve: The user wants to retrieve a specific entity from the remote DICOM archive.
2. Receive: The Digital Lightbox responds to storage requests.

Associations will be rejected,

- If the Called AE Title does not match the pre-configured AE Title
- If the conversion is enabled and the controlling application decides to reject it.

4.2.1.4.1 Activity – Retrieve

4.2.1.4.1.1 Associated Real-World Activity

On user selection of a specific DICOM entity a move request is performed. To receive the requested SOP instances a Storage SCP is invoked. The Storage SCP is only active during a DICOM Query/Retrieve C-MOVE request and automatically stopped after receive of the final C-MOVE response.

4.2.1.4.1.2 Proposed Presentation Contexts

Presentation Context Table			
Abstract Syntax	Transfer Syntax	Role	Ext. Neg
All SCP SOP Classes as listed in Table 4-1 and Table 4-3	All SCP Transfer Syntaxes as listed in Table 4-4	SCP	None
		SCP	None
		SCP	None

Table 4-7: Storage SCP Presentation Contexts.

4.2.1.4.1.3 SOP Specific Conformance

Digital Lightbox provides standard conformance to the DICOM Verification Service Class and to the DICOM Storage SOP Classes. No extended negotiation is implemented.

4.2.1.4.1.4 Presentation Context Acceptance Criterion

Digital Lightbox accepts multiple presentation contexts containing the same abstract syntax.

4.2.1.4.1.5 Transfer Syntax Selection Policy

The first Transfer Syntax encountered in the configuration file, which matches a Transfer Syntax offered for a given Presentation Context, will be selected as the accepted Transfer Syntax for that Presentation Context.

4.2.1.4.2 Activity – Receive

4.2.1.4.1.1 Associated Real-World Activity

As DICOM storage instances are received they are saved to the local file system. If the received instance is a duplicate of a previously received instance, the old file will be overwritten with the new one.

4.2.1.4.1.2 Proposed Presentation Contexts

Presentation Context Table			
Abstract Syntax	Transfer Syntax	Role	Ext. Neg
All SCP SOP Classes as listed in Table 4-1 and Table 4-3	All SCP Transfer Syntaxes as listed in Table 4-4	SCP	None
		SCP	None
		SCP	None

Table 4-8: Storage SCP Presentation Contexts.

4.2.1.4.1.3 SOP Specific Conformance

The Digital Lightbox provides standard conformance to the DICOM Verification Service Class and to the DICOM Storage SOP Classes. No extended negotiation is implemented.

4.2.1.4.1.4 Presentation Context Acceptance Criterion

The Digital Lightbox accepts multiple presentation contexts containing the same abstract syntax.

4.2.1.4.1.5 Transfer Syntax Selection Policy

The first Transfer Syntax encountered in the configuration file, which matches a Transfer Syntax offered for a given Presentation Context, will be selected as the accepted Transfer Syntax for that Presentation Context.

4.3 Network Interfaces

4.3.1 Physical Network Interface

Digital Lightbox supports the DICOM upper layer using TCP/IP. Digital Lightbox is indifferent to the physical medium over which TCP/IP executes. It inherits this from the operating system upon which it executes.

4.3.2 Additional Protocols

The usage of DNS and DHCP is possible and is based on the network configuration of the operating system upon which Digital Lightbox executes.

4.4 Configuration

4.4.1 AE Title / Presentation Address Mapping

Configuration of remote and local DICOM nodes can be performed with the graphical user interface of Digital Lightbox settings configuration program.

Digital Lightbox can configure several nodes representing remote Q/R Servers. On the corresponding settings page, application-wide global parameter and node-specific parameters can be entered.

4.4.1.1 Local AE Titles

The local AET for the Query/Retrieve SCU is an application-wide global parameter. The local AET for the Query/Retrieve SCU is also by default shared by the Storage SCP used by Query/Retrieve. But for each specified Query/Retrieve node it is possible to define a separate Storage SCP AET.

The local AET of the Digital Lightbox Storage SCP used by remote nodes is separate from the Query/Retrieve AET.

The listening port is an application-wide global parameter.

Application Entity	Default AE Title	Default TCP/IP Port
Digital Lightbox (Query/Retrieve)	LIGHTBOX_QR	5104
Digital Lightbox (Storage SCP only)	LIGHTBOX_STORE	104

4.4.1.2 Remote AE Title/Presentation Address Mapping

In Digital Lightbox you can specify several nodes for import. The IP address/hostname, AET and listening port may be configured for each DICOM network node separately within the Digital Lightbox settings configuration program's graphical user interface.

4.4.2 Parameters

Additional a timeout may be specified for each DICOM network archive separately.

Parameter	Configurable	Default Value
Timeout	Yes	30
Maximum PDU Size	No	28672

5 Media Interchange

Digital Lightbox supports DICOM media interchange for import of DICOM data:

- For import Digital Lightbox supports media interchange application profiles. To reflect this the support for the Standard General Purpose CD-R Interchange is added to provide the supported SOP Classes. Nevertheless Digital Lightbox is able to import DICOM files even without the existence of any DICOMDIR by scanning a given file system located on any media (e.g. HD, MOD, CD, DVD, Tapes, USB Drive) for any kind of DICOM files.

5.1 Implementation Model

5.1.1 Application Data Flow Diagram

With Digital Lightbox the user may browse DICOM file sets and import selected entities.



Figure 5-1: The media interchange application flow diagram

5.1.2 Functional Definition of Application Entity (AE)

Some communications and data transfer with remote AEs are accomplished utilizing the file system provided by the operating system upon which Digital Lightbox executes.

- File Set Reader:
Digital Lightbox loads DICOM data from the file. The reader supports the same SOP classes as the Storage SCP (see Table 4-3).

5.1.3 Sequencing Of Real World Activities

Not necessary.

5.1.4 File Meta Implementation Identifying Information

Digital Lightbox provides the same information as in chapter 4.2.1.2.4.

5.2 Application Entity Specifications

5.2.1 Media Interchange Profile

Digital Lightbox does not support any media interchange profiles.

5.3 Augmented And Private Application Profiles

Digital Lightbox does not support any augmented or private application profiles.

5.4 Media Configuration

Digital Lightbox uses the local AET configured for the Store SCP network service as source AET for the DICOM files.

6 Support Of Extended Character Sets

Digital Lightbox supports the

- ISO_IR 100 (ISO 8859-1:1987 Latin Alphabet No. 1 supplementary set)

7 Security Profiles

No security profiles are supported.

8 Annexes

8.1 IOD Contents

8.1.1 Usage Of Attributes From Received IODs

This section describes the requirements on the DICOM data, which can be displayed.

8.1.1.1 Images

Digital Lightbox accepts all images of the SOP Classes in Table 4-3. Though, there are some restrictions and special conversions:

- Images with an attribute (0028,0030) Pixel Spacing containing different values for x and y distance¹ will be ignored.

¹ To be more precise: If the difference between both values is greater than 0.001 mm.

8.2 Data Dictionary Of Private Attributes

None supported.

8.3 Coded Terminology And Templates

None supported.

8.4 Grayscale Image Consistency

Not supported.

8.5 Standard Extended/Specialized/Private Sop Classes

None supported.

8.6 Private Transfer Syntaxes

None supported.

9 Indexes

9.1 Index Of Tables

Table 1-1: Network services supported by Digital Lightbox	4
Table 1-2: Media Services supported by Digital Lightbox	4
Table 4-1: Supported Verification SOP Classes	13
Table 4-2: Supported Query/Retrieve SOP Classes.....	13
Table 4-3: Supported Storage SOP Classes	13
Table 4-4: Supported Transfer Syntaxes.....	14
Table 4-5: Proposed Presentation Contexts for Activity Find.....	15
Table 4-6: Proposed Presentation Contexts for Activity Move.....	15
Table 4-7: Storage SCP Presentation Contexts.....	16
Table 4-8: Storage SCP Presentation Contexts.....	17

9.2 Index Of Figures

Figure 4-1: The Query/Retrieve SCU application flow diagram	10
Figure 4-2: The Storage SCP application flow diagram	10
Figure 4-3: Sequencing of Query/Retrieve SCU and Storage SCP	12
Figure 5-1: The media interchange application flow diagram.....	19