

Technical Publication

DICOM Conformance Statement
Patient Browser 2.1

Document Revision 2

April 13, 2011

2011 © Copyright BrainLAB AG



1 Conformance Statement Overview

This is a conformance statement for the BrainLAB software Patient Browser. One main purpose of this software is to import and manage DICOM data.

The DICOM import part of the application is

- Browse and display of DICOM files (e.g. removable media)
- Query remote DICOM archives
- Retrieve DICOM data from archives
- Receive DICOM data from other DICOM nodes (e.g. archives or workstations) via the network

SOP Classes	User Of Service (SCU)	Provider Of Service (SCP)
Transfer		
Enhanced CT Image	No	Yes
Enhanced MR Image	No	Yes
Standard CT	No	Yes
Standard MR	No	Yes
Standard NM	No	Yes
Standard NM Retired	No	Yes
Standard PET	No	Yes
Query/Retrieve		
Patient Root Query/Retrieve Information Model - FIND	Yes	No
Patient Root Query/Retrieve Information Model - MOVE	Yes	No
Study Root Query/Retrieve Information Model - FIND	Yes	No
Study Root Query/Retrieve Information Model - MOVE	Yes	No

Table 1-1: Network services supported by Patient Browser

Media Storage Application Profile	Write Files (FSC or FSU)	Read Files (FSR)
Compact Disc – Recordable		
General Purpose CD–R	No	Yes

Table 1-2: Media Services supported by Patient Browser

2 Table Of Contents

1	Conformance Statement Overview	3
2	Table Of Contents	4
3	Introduction	6
3.1	Revision History	6
3.2	Audience	6
3.3	Remarks	6
3.4	Abbreviations	7
3.5	References	7
4	Networking	8
4.1	Implementation Model	8
4.1.1	Application Data Flow Diagram	8
4.1.2	Functional Definition of Application Entity (AE)	9
4.1.3	Sequencing Of Real World Activities	9
4.2	Application Entity Specifications	10
4.2.1	Patient Browser Specification	10
4.2.1.1	SOP Classes and Transfer Syntaxes	10
4.2.1.2	Association Policies	11
4.2.1.2.1	General	11
4.2.1.2.2	Number of Associations	11
4.2.1.2.3	Asynchronous Nature	11
4.2.1.2.4	Implementation Identifying Information	11
4.2.1.3	Association Initiation Policy	12
4.2.1.3.1	Activity – Find	12
4.2.1.3.2	Activity – Retrieve	13
4.2.1.4	Association Acceptance Policy	14
4.2.1.4.1	Activity – Receive	14
4.3	Network Interfaces	14
4.3.1	Physical Network Interface	14
4.3.2	Additional Protocols	15
4.4	Configuration	15
4.4.1	AE Title / Presentation Address Mapping	15
4.4.1.1	Local AE Titles	15
4.4.1.2	Remote AE Title/Presentation Address Mapping	15
4.4.2	Parameters	15
5	Media Interchange	16
5.1	Implementation Model	16
5.1.1	Application Data Flow Diagram	16
5.1.2	Functional Definition of Application Entity (AE)	16
5.1.3	Sequencing Of Real World Activities	16
5.1.4	File Meta Implementation Identifying Information	16
5.2	Application Entity Specifications	17
5.2.1.1	File Meta Information for the Application Entity	17
5.2.1.2	Real-World Activities	17
5.2.1.3	Activity – Import DICOM	17
5.2.1.3.1	Media Storage Application Profiles	17
5.3	Augmented And Private Application Profiles	18
5.4	Media Configuration	18

6	Support Of Extended Character Sets	19
7	Security Profiles	20
8	Annexes	21
8.1	IOD Contents	21
8.1.1	Usage Of Attributes From Received IODs	21
8.1.1.1	Images	21
8.2	Data Dictionary Of Private Attributes	21
8.3	Coded Terminology And Templates	21
8.4	Grayscale Image Consistency	21
8.5	Standard Extended/Specialized/Private Sop Classes	21
8.6	Private Transfer Syntaxes	21
9	Indexes	22
9.1	Index Of Tables	22
9.2	Index Of Figures	22

3 Introduction

3.1 Revision History

Document Version	Date of Issue	Author	Description
1	March 23, 2010		Initial version 2.0
2	April 13, 2011		Update for Patient Browser 2.1

3.2 Audience

This document is intended for hospital staff, health system integrators, software designers or implementers. It is assumed that the reader has a working understanding of DICOM.

3.3 Remarks

DICOM, by itself, does not guarantee interoperability. However, the Conformance Statement facilitates a first-level validation for interoperability between different applications supporting the same DICOM functionality. The Conformance Statement should be read and understood in conjunction with the DICOM Standard [1]. However, by itself it is not guaranteed to ensure the desired interoperability and a successful interconnectivity.

The user should be aware of the following important issues:

- The comparison of different conformance statements is the first step towards assessing interconnectivity between BrainLAB and non–BrainLAB equipment.
- This Conformance Statement is not intended to replace validation with other DICOM equipment to ensure proper exchange of information intended. An acceptance protocol is available to validate the desired level of connectivity.
- The DICOM standard will evolve to meet the users' future requirements. BrainLAB reserves the right to make changes to its products or to discontinue its delivery.

3.4 Abbreviations

There are a variety of terms and abbreviations used in the document that are defined in the DICOM Standard. Abbreviations and terms are as follows:

AE	DICOM Application Entity
AET	Application Entity Title
CD	Compact Disk
CD-R	Compact Disk Recordable
DVD	Digital Versatile Disc
FSC	File-Set Creator
FSU	File-Set Updater
FSR	File-Set Reader
HD	Hard Disk
IOD	(DICOM) Information Object Definition
ISO	International Standard Organization
MOD	Magneto Optical Disk
PDU	DICOM Protocol Data Unit
Q/R	Query and Retrieve
SCU	DICOM Service Class User (DICOM client)
SCP	DICOM Service Class Provider (DICOM server)
SOP	DICOM Service-Object Pair

3.5 References

- [1] Digital Imaging and Communications in Medicine (DICOM) 3.0, NEMA PS 3.1-3.18 – 2006

4 Networking

4.1 Implementation Model

The BrainLAB Patient Browser application is an implementation of:

- A Query/Retrieve SCU to query DICOM archives and to initiate a move request for the queried archive.
- A Media File Set Reader to load DICOM data from a file system.
- A Storage SCP that receives DICOM data from other DICOM archives or workstations.
- A visualization of imported DICOM data

4.1.1 Application Data Flow Diagram

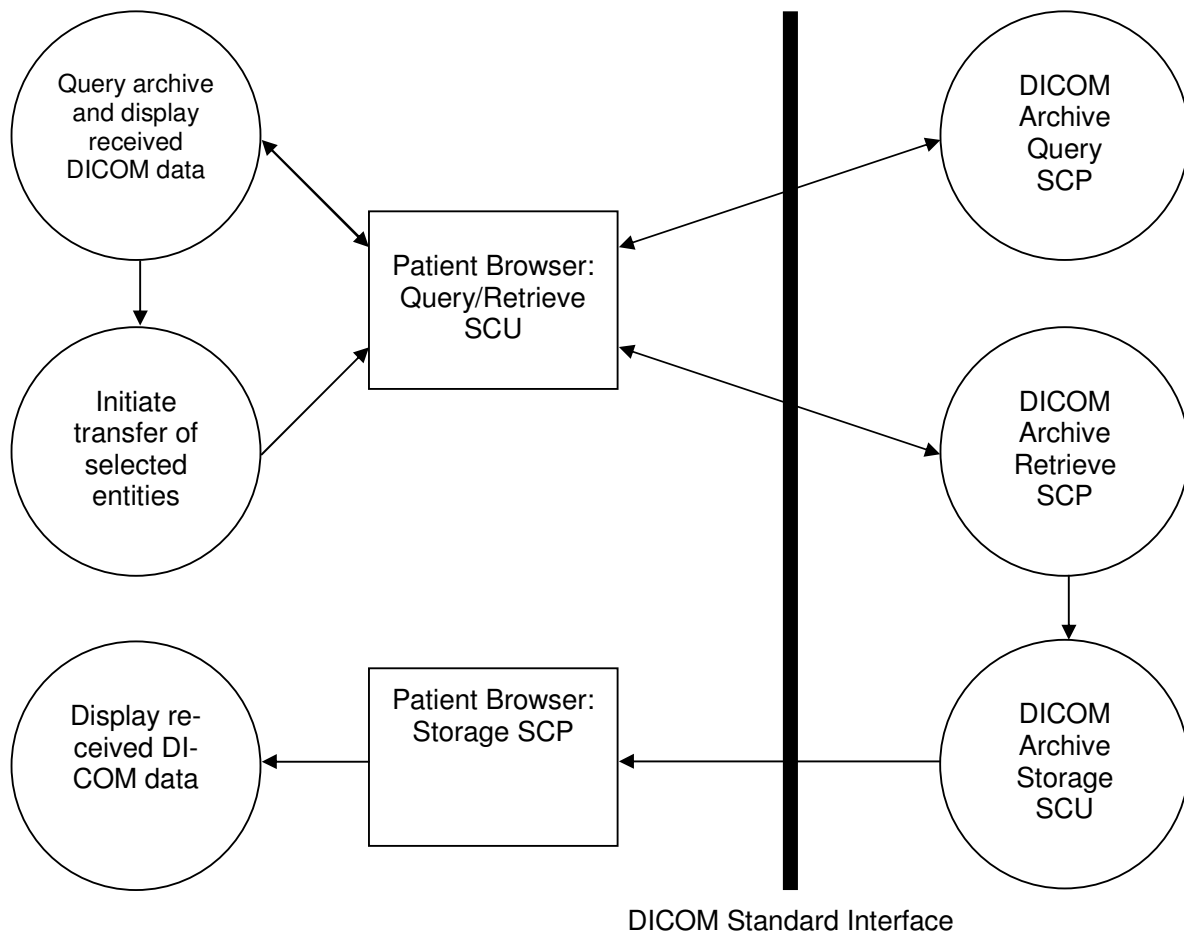

Figure 4-1: The Query/Retrieve SCU application flow diagram

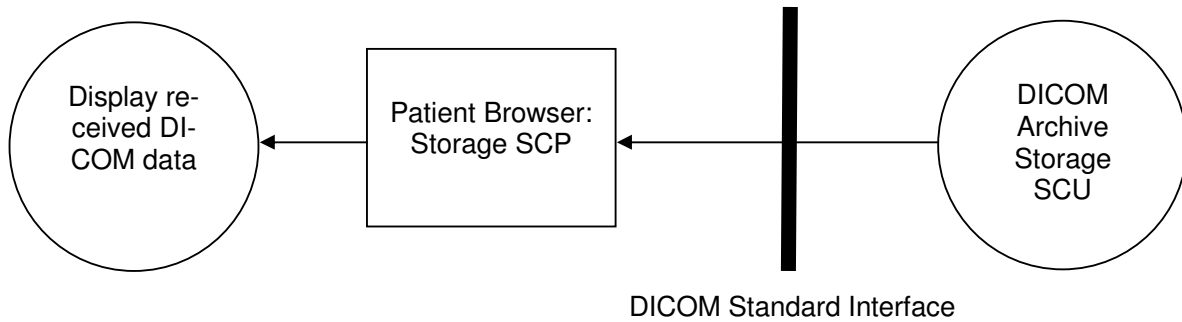

Figure 4-2: The Storage SCP application flow diagram

4.1.2 Functional Definition of Application Entity (AE)

Some communications and data transfer with remote AEs are accomplished utilizing the DICOM protocol over a network using the TCP/IP protocol stack.

- Query and Retrieve:
The user wants to find a certain dataset in a DICOM archive. Patient Browser initiates an association as a Q/R SCU negotiating all models. The find request can be performed (depending on the negotiated models) on all DICOM levels (patient, study, series or instance). A move request will be performed on series level or on instance level.
- Storage SCP:
With the start of the Patient Browser a DICOM Storage SCP is invoked. It accepts any association with a Storage SCU negotiating any of the SOP Classes listed in Table 4-3.

Further, during a move operation a DICOM Storage SCP is invoked. Patient Browser accepts an association with a Storage SCU negotiating any of the SOP Classes listed in Table 4-3.

4.1.3 Sequencing Of Real World Activities

Patient Browser Query/Retrieve SCU performs a sequencing of real world activities as follows:

1. Query Archive and display received DICOM data:
 - a. Send DICOM Query/Retrieve C-FIND request.
 - b. Receive DICOM Query/Retrieve C-FIND responses.
2. User selects data to retrieve.
3. Initiate transfer of selected entities:
 - a. Send a DICOM Query/Retrieve C-MOVE request
 - b. Receive DICOM C-STORE requests with the requested SOP instances.
 - c. Receive DICOM Query/Retrieve C-MOVE responses

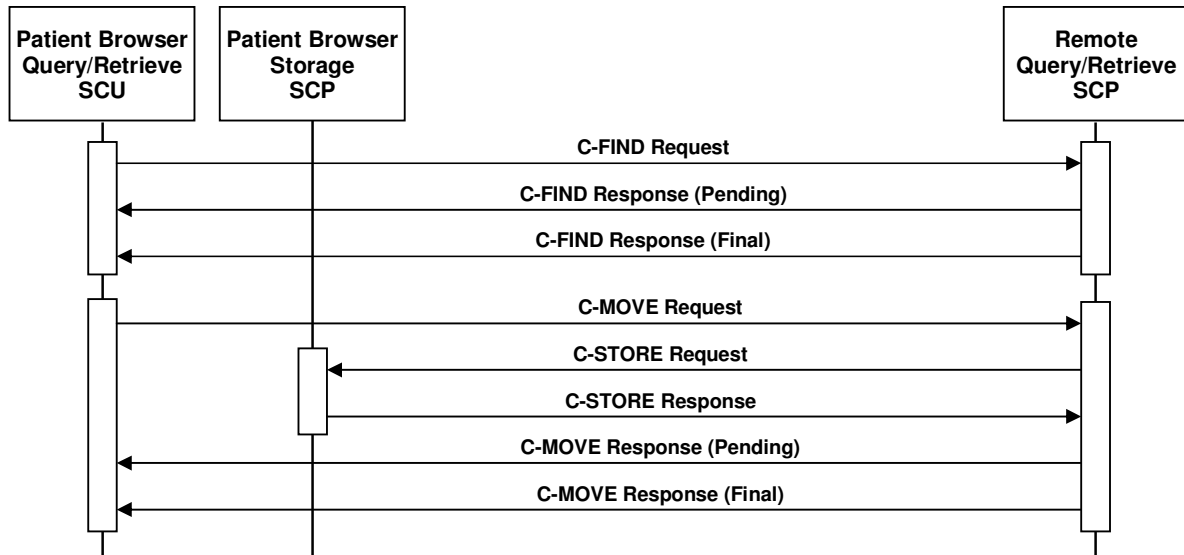

Figure 4-3: Sequencing of Query/Retrieve SCU and Storage SCP

4.2 Application Entity Specifications

4.2.1 Patient Browser Specification

4.2.1.1 SOP Classes and Transfer Syntaxes

Patient Browser sends or receives a C-ECHO request in order to test the connection to a remote AE. It provides standard conformance to the following DICOM V3.0 SOP Classes:

SOP Class Name	SOP Class UID	SCU	SCP
Verification SOP Class	1.2.840.10008.1.1	Yes	Yes

Table 4-1: Supported Verification SOP Classes

Patient Browser is able to query a remote archive. It provides Standard Conformance to the following DICOM V3.0 SOP Classes:

SOP Class Name	SOP Class UID	SCU	SCP
Patient Root Query/Retrieve Information Model - FIND	1.2.840.10008.5.1.4.1.2.1.1	Yes	No
Patient Root Query/Retrieve Information Model - MOVE	1.2.840.10008.5.1.4.1.2.1.2	Yes	No
Study Root Query/Retrieve Information Model - FIND	1.2.840.10008.5.1.4.1.2.2.1	Yes	No
Study Root Query/Retrieve Information Model - MOVE	1.2.840.10008.5.1.4.1.2.2.2	Yes	No

Table 4-2: Supported Query/Retrieve SOP Classes

Patient Browser imports and exports DICOM image data. It provides Standard Conformance to the following DICOM V3.0 SOP Classes:

SOP Class Name	SOP Class UID	SCU	SCP
Enhanced CT Image	1.2.840.10008.5.1.4.1.1.2.1	No	Yes
Enhanced MR Image	1.2.840.10008.5.1.4.1.1.4.1	No	Yes
Standard CT	1.2.840.10008.5.1.4.1.1.2	No	Yes
Standard MR	1.2.840.10008.5.1.4.1.1.4	No	Yes
Standard NM	1.2.840.10008.5.1.4.1.1.20	No	Yes
Standard NM Retired	1.2.840.10008.5.1.4.1.1.5	No	Yes
Standard PET	1.2.840.10008.5.1.4.1.1.128	No	Yes

Table 4-3: Supported Storage SOP Classes

Patient Browser supports the following transfer syntaxes. In an association negotiation the syntaxes are proposed in the order of appearance in the following tables.

Transfer Syntax Name	Transfer Syntax UID	SCU	SCP
DICOM Implicit VR Little Endian	1.2.840.10008.1.2	Yes	Yes
DICOM Explicit VR Little Endian	1.2.840.10008.1.2.1	Yes	Yes
DICOM Explicit VR Big Endian	1.2.840.10008.1.2.2	Yes	Yes

Table 4-4: Supported Standard Transfer Syntaxes

Transfer Syntax Name	Transfer Syntax UID	SCU	SCP
JPEG Lossless, Non-Hierarchical, First-Order Prediction (Process 14 [Selection Value 1]): Default Transfer Syntax for Lossless JPEG Image Compression	1.2.840.10008.1.2.4.70	Yes	Yes

Table 4-5: Supported Compression Transfer Syntaxes

4.2.1.2 Association Policies

4.2.1.2.1 General

The DICOM standard application context name for DICOM 3.0 is always proposed:

Application Context Name	1.2.840.10008.3.1.1.1
--------------------------	-----------------------

4.2.1.2.2 Number of Associations

Maximum number of simultaneous Associations (Initiator)	2 (configurable)
Maximum number of simultaneous Associations (Acceptor)	unrestricted

4.2.1.2.3 Asynchronous Nature

The Patient Browser does not support asynchronous communication (multiple outstanding transactions over a single association).

Maximum number of outstanding asynchronous transactions	1
---	---

4.2.1.2.4 Implementation Identifying Information

The implementation information for this Application Entity is:

Implementation Class UID	1.2.276.0.20.1.1.14.2.1.0
Implementation Version Name	PatientBrowse2.1

4.2.1.3 Association Initiation Policy

Patient Browser initiates an association in these cases:

1. Find: The user tries to find a specific entity in a remote DICOM archive.
2. Retrieve: The user wants to retrieve a specific entity from the remote DICOM archive.

4.2.1.3.1 Activity – Find

4.2.1.3.1.1 Description and Sequencing of Activities

A DICOM Query/Retrieve C-FIND request is performed when the user queries the remote DICOM archive for patients, studies, series or instances.

4.2.1.3.1.2 Proposed Presentation Contexts

Presentation Context Table			
Abstract Syntax	Transfer Syntax	Role	Ext. Neg.
All SCU SOP Classes listed in Table 4-1 and all FIND SCU SOP Classes as listed in Table 4-2	All SCU Transfer Syntaxes as listed in Table 4-4	SCU	None
		SCU	None
		SCU	None

Table 4-6: Proposed Presentation Contexts for Activity Find.

4.2.1.3.1.3 SOP Specific Conformance

Patient Browser provides standard conformance to the DICOM Verification Service Class and to the DICOM Query/Retrieve FIND SOP Classes. No extended negotiation is implemented.

A C-FIND can be executed on all levels. On a lower level, all key attributes of the higher levels are included in the query (i.e. no hierarchical queries are performed). C-FIND's on IMAGE level can be disabled via a configuration option.

A C-CANCEL will be sent if the user aborts the search process or the Patient Browser is shut down. If the remote server does not react to a C-CANCEL, the association is aborted.

Attribute Name	Tag	Types of Matching
Patient Level (Patient Root Q/R Information Model)		
Study Level (Study Root Q/R Information Model)		
Patient's Name	(0010,0010)	S, *, U
Patient ID	(0010,0020)	S, *, U
Patient's Birth Date	(0010,0030)	U
Patient's Sex	(0010,0040)	U
Study Level		
Study Date	(0008,0020)	S, R, U
Accession Number	(0008,0050)	S, *, U

Attribute Name	Tag	Types of Matching
Study Instance UID	(0020,000D)	UNIQUE
Study Time	(0008,0030)	U
Study Description	(0008,1030)	U
Series Level		
Series Instance UID	(0020,000E)	UNIQUE
Series Number	(0020,0011)	U
Series Description	(0008,103E)	U
Modality	(0008,0060)	U
No. of Series Rel. Instances	(0020,1209)	U
Instance Level		
SOP Instance UID	(0008,0018)	UNIQUE
Instance Number	(0020,0013)	U

Table 4-7: Patient Root and Study Root Request Identifier for FIND-SCU

The types of Matching supported by the C-FIND SCU:

- An "S" indicates the identifier attribute uses Single Value Matching.
- An "R" indicates Range Matching.
- A "*" indicates wildcard matching.
- A 'U' indicates Universal Matching (i.e. the attributes value is empty and shall only be returned, not used as a filter key).
- "UNIQUE" indicates that this is the Unique Key for that query level, in which case Universal Matching or Single Value Matching is used depending on the query level.

4.2.1.3.2 Activity – Retrieve

4.2.1.3.2.1 Description and Sequencing of Activities

On user selection of a specific DICOM study or series (depends on the available SOP Class for Query/Retrieve), a move request is performed. The storage target for receiving the DICOM data (the AET with which the move-request is equipped) is the Patient Browser application itself.

The Move operation only is performed on SERIES level.

A C-CANCEL will be sent if the user selects a different image series or if the Patient Browser is shut down. If the remote server does not react to a C-CANCEL, the association is aborted.

The Move operation only can be invoked after a Find operation. See chapter 4.1.3 for a detailed sequencing diagram.

4.2.1.3.2.2 Proposed Presentation Contexts

Presentation Context Table			
Abstract Syntax	Transfer Syntax	Role	Ext. Neg.
All SCU SOP Classes listed in Table 4-1 and all SCU MOVE SOP Classes as listed in Table 4-2	All SCU Transfer Syntaxes as listed in Table 4-4	SCU	None
		SCU	None
		SCU	None

Table 4-8: Proposed Presentation Contexts for Activity Move.

4.2.1.3.2.3 SOP Specific Conformance

Patient Browser provides standard conformance to the DICOM Verification Service Class and to the DICOM Query/Retrieve MOVE SOP Classes. No extended negotiation is implemented.

4.2.1.4 Association Acceptance Policy

Patient Browser accepts an association in this case:

1. Receive:
 - The user wants to retrieve a specific entity from the remote DICOM archive.
 - The Patient Browser responds to storage requests.

4.2.1.4.1 Activity – Receive

4.2.1.4.1.1 Associated Real-World Activity

As DICOM storage instances are received they are saved to the local file system. If the received instance is a duplicate of a previously received instance, the new instance will not be stored.

4.2.1.4.1.2 Proposed Presentation Contexts

Presentation Context Table			
Abstract Syntax	Transfer Syntax	Role	Ext. Neg
All SCP SOP Classes as listed in Table 4-1 and Table 4-3	All SCP Transfer Syntaxes as listed in Table 4-4 and Table 4-5	SCP	None
		SCP	None
		SCP	None

Table 4-9: Storage SCP Presentation Contexts.

4.2.1.4.1.3 SOP Specific Conformance

The Patient Browser provides standard conformance to the DICOM Verification Service Class and to the DICOM Storage SOP Classes. No extended negotiation is implemented.

4.2.1.4.1.4 Presentation Context Acceptance Criterion

The Patient Browser accepts multiple presentation contexts containing the same abstract syntax.

4.2.1.4.1.5 Transfer Syntax Selection Policy

The first Transfer Syntax encountered in the configuration file, which matches a Transfer Syntax offered for a given Presentation Context, will be selected as the accepted Transfer Syntax for that Presentation Context.

4.3 Network Interfaces

4.3.1 Physical Network Interface

Patient Browser supports the DICOM upper layer using TCP/IP. Patient Browser is indifferent to the physical medium over which TCP/IP executes. It inherits this from the operating system upon which it executes.

4.3.2 Additional Protocols

The usage of DNS and DHCP is possible and is based on the network configuration of the operating system upon which Patient Browser executes.

4.4 Configuration

4.4.1 AE Title / Presentation Address Mapping

Configuration of remote and local DICOM nodes can be performed with the graphical user interface of Patient Browser settings configuration program.

Patient Browser can configure several nodes representing remote Q/R Servers. On the corresponding settings page, application-wide global parameter and node-specific parameters can be entered.

4.4.1.1 Local AE Titles

The Local AET and the Move Destination AET for the Query/Retrieve SCU can be configured for each remote Q/R Server.

The AET of the Storage SCP does not need to be configured, since the Patient Browser accepts any called AET. It is recommended to use BRAINLAB_STORE. One Storage SCP AET is reserved for intraoperative images. Images sent to this AET are subject to automatic processing by the Patient Browser application.

Application Entity	Default AE Title	Default TCP/IP Port
Patient Browser (Query/Retrieve)	BRAINLAB_QR	104
Patient Browser (Storage SCP only)	BRAINLAB_STORE	104
Patient Browser (Storage SCP in-traoperative images)	IntraOP	104

4.4.1.2 Remote AE Title/Presentation Address Mapping

In Patient Browser you can specify several nodes for import. The IP address/hostname, AET and listening port may be configured for each DICOM network node separately within the Patient Browser settings configuration program's graphical user interface.

4.4.2 Parameters

Additional a timeout may be specified for each DICOM network archive separately.

Parameter	Configurable	Default Value
Timeout	Yes	30
Maximum PDU Size	No	64234

5 Media Interchange

Patient Browser supports DICOM media interchange for import of DICOM data:

- For import Patient Browser supports media interchange application profiles. To reflect this, the support for the Standard General Purpose CD-R Interchange is added to provide the supported SOP Classes. Nevertheless Patient Browser is able to import DICOM files even without the existence of any DICOMDIR by scanning a given file system located on any media (e.g. HD, MOD, CD, DVD, Tapes, USB Drive) for any kind of DICOM files.

5.1 Implementation Model

5.1.1 Application Data Flow Diagram

With Patient Browser the user may browse DICOM file sets and import selected entities.

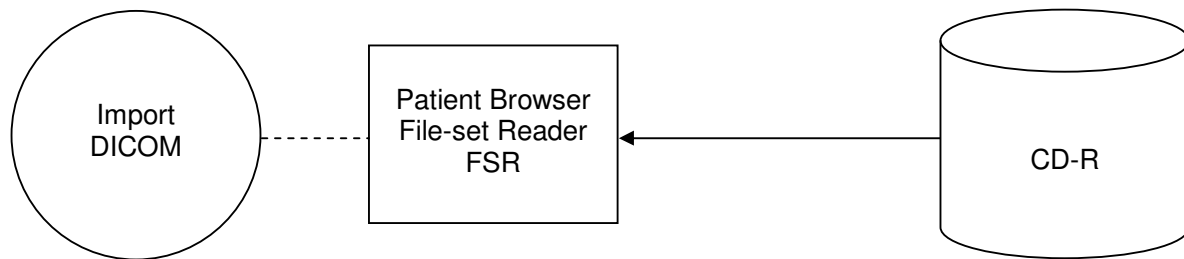

Figure 5-1: The media interchange application flow diagram

5.1.2 Functional Definition of Application Entity (AE)

Some communications and data transfer with remote AEs are accomplished utilizing the file system provided by the operating system upon which Patient Browser executes.

- File Set Reader:
Patient Browser loads DICOM data from the file. The reader supports the same SOP classes as the Storage SCP (see Table 4-3).

5.1.3 Sequencing Of Real World Activities

Not necessary.

5.1.4 File Meta Implementation Identifying Information

Patient Browser provides the same information as in chapter 4.2.1.2.4.

5.2 Application Entity Specifications

Patient Browser supports the following Media Interchange Profiles:

AE Related Application Profiles, Real-World Activities, and Roles			
Supported APs	Real World Activity	Roles	SC Option
STD-GEN-CD	Import DICOM	FSR	Interchange

Table 5-1: Supported Media Interchange Profiles.

5.2.1.1 File Meta Information for the Application Entity

The Source Application Entity Title included in the File Meta Header is configurable. It is the same as the local AET of the network configuration (see section 4.4.1.1)

5.2.1.2 Real-World Activities

5.2.1.3 Activity – Import DICOM

Patient Browser acts as an FSR using the Interchange option

- When requested to provide a directory listing it will read the File-set and display the DICOM-DIR directory entries for all SOP Instances in the File-set.
- When requested to import the selected entries from directory listing, only those SOP Instances are loaded that correspond to the Application Profile STD-GEN-CD.
- For the list of Application Profiles invoking this AE see Table 5-1. The supported SOP Classes see Table 4-3.

5.2.1.3.1 Media Storage Application Profiles

Patient Browser supports the STD-GEN-CD Application Profile.

5.2.1.3.1.1 Options

Supported transfer syntaxes for the media profiles:

Transfer Syntax Name	Transfer Syntax UID
DICOM Implicit VR Little Endian	1.2.840.10008.1.2
DICOM Explicit VR Little Endian	1.2.840.10008.1.2.1
DICOM Explicit VR Big Endian	1.2.840.10008.1.2.2
JPEG Baseline (Process 1): Default Transfer Syntax for Lossy JPEG 8 Bit Image Compression	1.2.840.10008.1.2.4.50
JPEG Extended (Process 2 & 4): Default Transfer Syntax for Lossy JPEG 12 Bit Image Compression (Process 4 only)	1.2.840.10008.1.2.4.51
JPEG Lossless, Non-Hierarchical, First-Order Prediction (Process 14 [Selection Value 1]): Default Transfer Syntax for Lossless JPEG Image Compression	1.2.840.10008.1.2.4.70
RLE Lossless	1.2.840.10008.1.2.5

Table 5-2: Supported Media Profile Transfer Syntaxes

The Offline-Media Application Entity supports the SOP Classes and Transfer Syntaxes listed in the Table below:

SOP Classes	Transfer Syntaxes
All SCP SOP Classes listed in Table 4-3	All SCP Transfer Syntaxes listed in Table 5-2

For further information see section 8.1.1 on acceptance of SOP Instances (i.e. whether Patient Browser is able to import and convert the DICOM data).

5.3 Augmented And Private Application Profiles

Patient Browser does not support any augmented or private application profiles.

5.4 Media Configuration

Patient Browser uses the local AET configured for the Store SCP network service as source AET for the DICOM files.

6 Support Of Extended Character Sets

Patient Browser supports the

- ISO_IR 100 (ISO 8859-1:1987 Latin Alphabet No. 1 supplementary set)

7 Security Profiles

No security profiles are supported.

8 Annexes

8.1 IOD Contents

8.1.1 Usage Of Attributes From Received IODs

This section describes the requirements on the DICOM data, which can be displayed.

8.1.1.1 Images

Patient Browser accepts all images of the SOP Classes in Table 4-3. Though, there are some restrictions and special conversions:

- Images with an attribute (0028,0030) Pixel Spacing containing different values for x and y distance¹ will be ignored.

8.2 Data Dictionary Of Private Attributes

None supported.

8.3 Coded Terminology And Templates

None supported.

8.4 Grayscale Image Consistency

Not supported.

8.5 Standard Extended/Specialized/Private Sop Classes

None supported.

8.6 Private Transfer Syntaxes

None supported.

¹ To be more precise: If the difference between both values is greater than 0.001 mm.

9 Indexes

9.1 Index Of Tables

Table 1-1: Network services supported by Patient Browser	3
Table 1-2: Media Services supported by Patient Browser	3
Table 4-1: Supported Verification SOP Classes	10
Table 4-2: Supported Query/Retrieve SOP Classes.....	10
Table 4-3: Supported Storage SOP Classes	11
Table 4-4: Supported Standard Transfer Syntaxes	11
Table 4-5: Supported Compression Transfer Syntaxes	11
Table 4-6: Proposed Presentation Contexts for Activity Find.....	12
Table 4-7: Patient Root and Study Root Request Identifier for FIND-SCU	13
Table 4-9: Proposed Presentation Contexts for Activity Move.....	14
Table 4-10: Storage SCP Presentation Contexts.	14
Table 5-1: Supported Media Interchange Profiles.	17
Table 5-2: Supported Media Profile Transfer Syntaxes	17

9.2 Index Of Figures

Figure 4-1: The Query/Retrieve SCU application flow diagram	8
Figure 4-2: The Storage SCP application flow diagram.....	9
Figure 4-4: Sequencing of Query/Retrieve SCU and Storage SCP	10
Figure 5-1: The media interchange application flow diagram	16